

INSTRUCTION MANUAL

DRAKE
MODEL
TR-6
6M TRANSCEIVER



R. L. DRAKE COMPANY • MIAMISBURG, OHIO

TABLE OF CONTENTS

| | | |
|------|--|----|
| I. | General Description | 3 |
| II. | Specifications | |
| | A. General | 4 |
| | B. Receiver | 5 |
| | C. Transmitter | 6 |
| | D. Power Requirements | 7 |
| III. | Unpacking | 7 |
| IV. | Manual Controls, Jacks, and Indicators | |
| | A. Front Panel | 8 |
| | B. Side | 10 |
| | C. Rear | 12 |
| V. | Installation | |
| | A. Antenna | 14 |
| | B. Power | 14 |
| | C. Speaker and Headphones | 14 |
| | D. Key and Microphone | 14 |
| | E. Location | 15 |
| | F. Fixed | 16 |
| | G. Mobile | 16 |
| | H. Installation With Other Accessories | 17 |
| | I. Use in Aircraft | 18 |
| VI. | Tuning Procedure | 21 |
| VII. | Operation | |
| | A. SSB VOX | 24 |
| | B. SSB PTT | 24 |
| | C. CW | 25 |
| | D. AM | 25 |
| | E. General Precautions Near Band Edges | 26 |
| | F. Operation With Linear Amplifiers | 26 |
| | G. RTTY Operation | 27 |

| | | |
|-------|---------------------------|----|
| VIII. | Theory of Operation | |
| | A. Receiver Circuitry | 28 |
| | B. Transmitter Circuitry | 29 |
| | C. Transceiving Circuitry | 29 |
| IX. | Service Data | 33 |
| X. | Alignment Instructions | 35 |
| XI. | Electrical Parts List | 42 |
| XII. | Accessory Information | 54 |

ILLUSTRATIONS

| | | |
|----------|---|----------|
| Fig. #1 | Front View | 3 |
| Fig. #2 | Side View | 11 |
| Fig. #3 | Rear View | 13 |
| Fig. #4 | Microphone Connection | 15 |
| Fig. #5 | Connection of TR-6 with AC-3, RV-6, and Linear Amplifier | 18 |
| Fig. #6 | Connection of TR-6 with DC Power Supply | 19 |
| Fig. #7 | Connection of TR-6 with AC-4, MS-4, R-4B, and SC-2 | 19 |
| Fig. #8 | Viewing Angle Options | 20 |
| Fig. #9 | Block Diagram | 30 |
| Fig. #10 | Voltage Chart | 31 |
| Fig. #11 | Resistance Chart | 32 |
| Fig. #12 | RF Voltage Chart | 34 |
| Fig. #13 | Bottom View | 40 |
| Fig. #14 | Top View | 41 |
| Fig. #15 | Accessory Crystal View | 53 |
| Fig. #16 | Schematic Diagram | Fold-out |

I. GENERAL DESCRIPTION

The R.L. Drake model TR-6 is a radio transceiver which, in conjunction with an external fixed or mobile power supply and a suitable antenna, permits two way radio communications on any frequency in the 6 meter amateur band as well as on adjacent frequencies.

The mode of transmission and reception is switchable. The unit is capable of communicating in the SSB, AM, FSK, and keyed CW modes. Appropriate modulators and detectors are provided for each mode, as well as switching for appropriate IF filters.

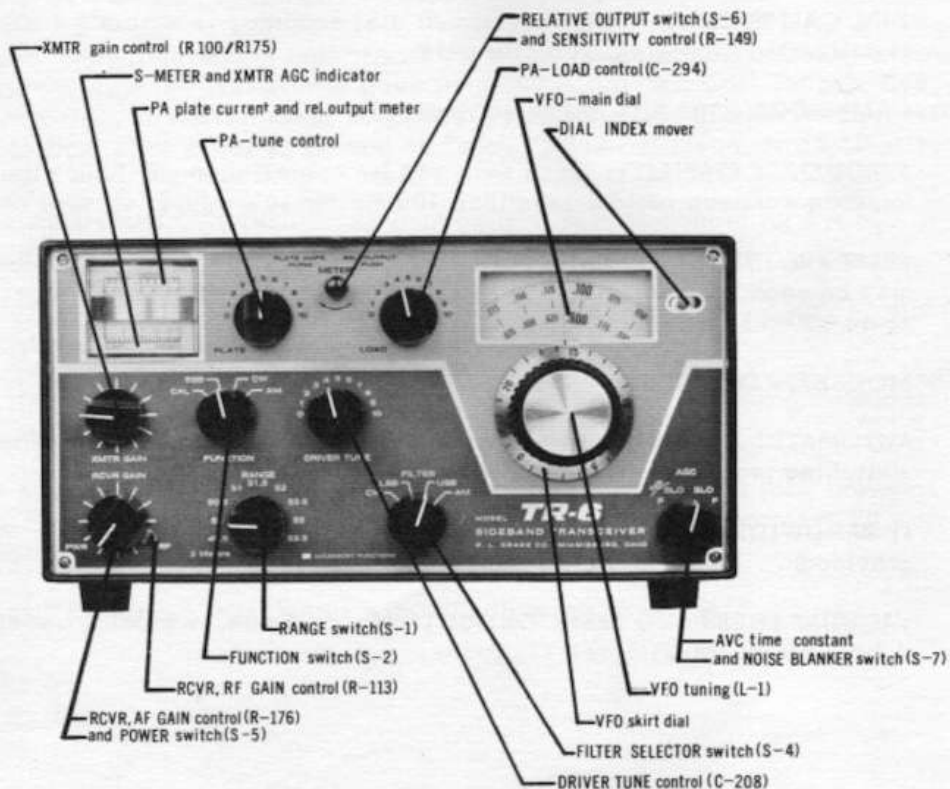

FIG. 1—FRONT VIEW

II. SPECIFICATIONS

A. GENERAL SPECIFICATIONS

SIZE: 5 - 7/16" high, 10 - 3/4" wide, 14 - 1/4" deep (cabinet without feet and knobs).

WEIGHT: 15 - 3/4 lbs.

FREQUENCY COVERAGE: 49.4 to 54.0 MHz in 9 overlapping 600 KHz ranges (49.9 to 51.0 MHz with crystals supplied).

FREQUENCY ADJUSTMENT: Solid state linear permeability tuned VFO permits continuous frequency coverage.

DIAL CALIBRATION: 1 KHz divisions; dial accuracy is within ± 1 KHz if calibrated at nearest 100 KHz point.

CALIBRATOR: 100 KHz calibrator built in.

FREQUENCY STABILITY: Less than 100 Hz overall drift per hour after 15 minutes warm-up period; less than 100 Hz for 10% supply voltage change.

SPLIT FREQUENCY OPERATION: Transmitting and receiving frequencies may be separated by up to 600 KHz by use of the RV-6 or FF-1 accessories or an external receiver.

MODES OF OPERATION: SSB, AM, and CW.

AUTOMATIC T/R SWITCHING: With multi-contact relay. Front panel switching provided for 2m-transverters.

IF BANDWIDTHS: 4 filters switchable from front panel (USB filter provided).

VACUUM TUBES AND SEMICONDUCTORS: 19 tubes, 9 bipolar transistors, 4 field effect transistors, 12 diodes.

B. RECEIVER SPECIFICATIONS

SENSITIVITY: Less than 1/10 microvolt for 10 dB S+N/N ratio at 2.4 KHz bandwidth.

SELECTIVITY: 6 dB bandwidth 2.4 KHz nominal. 50 dB bandwidth 7 KHz maximum, with USB filter provided. Accessory filters, switchable from front panel available for LSB, AM (6 KHz at 6 dB), and CW (.3 KHz at 6 dB).

AUDIO RESPONSE: 400 to 2800 Hz at 6 dB.

INPUT: 50 ohms unbalanced.

OUTPUT: 4 ohms unbalanced, speaker and headphone output provided.

OUTPUT POWER: 2 watts at 10% HD.

AVC: Output variation less than 3 dB for 60 dB input change. Drake AVC system provides fast attack (less than 100 micro-seconds) for pop-free, pump-free, distortion-less automatic volume control. Release time switchable from front panel (1 second on "slow", 200 milliseconds on "fast").

MANUAL GAIN CONTROLS: RF gain control sets threshold for AVC; AF gain control.

DETECTORS: Switchable from front panel. Product detector for SSB and CW, envelope detector for AM.

NOISE BLANKER: On-off switch for accessory noise blanker provided on front panel.

14 MHz INPUT: 13.9 to 14.5 MHz receiving input/output jack provided for converters and/or outboard IF receivers. T/R muting contact for outboard receiver provided.

S-METER: Input level meter with 100 dB range provided.

C. TRANSMITTER SPECIFICATIONS

POWER INPUT: 300 W minimum PEP on SSB, 300 W PEP (75 W peak carrier compatible with SSB amplifiers) on AM. 260 W CW.

OUTPUT IMPEDANCE: 50 ohms nominal, unbalanced, 2:1 maximum SWR, loading adjustable from front panel.

MODES: SSB (upper sideband provided, lower sideband with accessory filter) AM (controlled carrier screen modulator built in). CW (grid block keying shaped for click free keying). Modes selectable with front panel switch.

AGC: Amplified automatic gain control prevents flat-topping and provides moderate speech compression in the SSB mode.

CARRIER INSERTION AND SHIFT: Automatic carrier insertion on AM, shift carrier system on CW.

INPUTS: Closed circuit type key jack for CW; high impedance high level microphone input on SSB and AM, 3 mv peak RMS minimum required for full PEP output. Manual gain control for CW and SSB/AM provided on front panel.

VOX AND PTT: VOX and ANTI-VOX built in. Separate VOX and ANTI-VOX gain controls provided. PTT contact provided on microphone jack. VOX also effective on AM and keyed CW, providing automatic semi break-in CW.

AUDIO RESPONSE: 400 to 2800 Hz at 6 dB.

CARRIER AND SIDEBAND SUPPRESSION: 40 dB minimum sideband suppression above 1 KHz. 50 dB minimum carrier suppression.

DISTORTION PRODUCTS: Down 30 dB minimum from PEP level.

MONITORING AND METERING: Final plate current, AGC action, and relative output can be read on meters. Sidetone with separately adjustable volume provided for keyed CW.

14 MHz OUTPUT: 13.9 to 14.5 MHz transmitting output for 2m-transverter.

D. POWER REQUIREMENTS

1. 650 volts DC at .5 A maximum with good regulation.
2. 250 volts DC at .175 A with low ripple.
3. -60 volts adjustable into 30 K load.
4. 12.6 volts at 5.5 A continuous.

The R.L. Drake models AC-3 and AC-4 power supplies (for 115/230 volt AC input 50 to 400 Hz), as well as the DC-3, DC-4, and DC-24 (for 12 volt or 24 volt, respectively, DC input), provide all necessary voltages for the operation of the TR-6.

III. UNPACKING

Carefully remove your TR-6 from its packing carton and examine it closely for signs of shipping damage. Should any be apparent, notify the delivering carrier immediately, stating the full extent of the damage.

Fill out and mail the enclosed registration card so that your warranty will be effective.

Save the packing material. You may need it later for reshipment or storage.

Inspect the packing material closely before putting it away to be sure you have not overlooked the Switchcraft type S-230 and 229 plugs and other hardware shipped with the TR-6.

Before starting to install and operate your TR-6, you should familiarize yourself thoroughly with the functions of the different controls as described in the next section.

IV. MANUAL CONTROLS AND JACKS

A. FRONT PANEL CONTROLS (see figure 1)

1. **MAIN TUNING** - The main tuning knob of the TR-6 determines the frequency on which the TR-6 transmits and receives. Each division around the calibrated skirt on this knob is equal to 1 KC and each each division on the main tuning dial is equal to 25 KC. The small red knob just to the right of the dial scale is provided for adjusting the position of the indicator line for calibration. The knob skirt is also adjustable by pushing it in slightly and rotating it in the desired direction, while holding the main tuning knob stationary.
2. **RCVR GAIN** - The RCVR GAIN control consists of two controls with concentric shafts. The lever controls the maximum RF gain of the receiver by varying the amount of negative bias applied to the grids of the AGC controlled tubes and transistor.

The knob adjusts the audio gain by regulating the input to the grid of the audio power amplifier tube. The transceiver power switch is operated at the extreme counter clockwise end of rotation of this knob.

3. **XMTR GAIN** - This control regulates the microphone gain on AM and SSB. When the unit is operated on CW, it is used to adjust the RF drive to the proper level.

This control is connected so that it regulates the VOX sensitivity as well as the audio drive to the balanced modulator. Since all changes in level due to the type mic, how close or loud you talk, etc., affect equally the VOX and audio drive requirements, this eliminates the necessity for changing the VOX gain control, located on the side of the TR-6 chassis, once it is set properly.

4. **FUNCTION** - The FUNCTION SWITCH is a four-position switch which determines the mode of operation of the TR-6.

In the SSB position, the receiver portion functions until the transmitter is energized either by talking into the microphone or pressing the push to talk switch.

In the CAL position, the 100 KC crystal calibrator is switched on for calibration purposes. The receive and transmit functions operate the same way as in the SSB position.

The FILTER switch must be in either the USB or LSB position, depending on which sideband is desired.

Note that a CW key, if used, must be either closed or unplugged to obtain RF-output on SSB.

In the CW position, the receiver portion functions until a key plugged into the key jack, is closed. The TR-6 then goes into the transmit mode, a CW sidetone is energized, and the carrier is shifted up by 1 KHz from the receiver zero beat frequency. It will remain on transmit during CW keying and will return to receive when keying is stopped briefly.

Note that no RF output will be obtained on CW or AM when the lower sideband filter is switched in.

On the AM position, a controlled carrier screen modulator is incorporated for AM transmission, and a diode detector is incorporated for AM reception. Transmit/receive switching is accomplished by VOX or PTT as on SSB.

5. RANGE - The RANGE switch is a ten position switch which selects the desired segment of the band.

Note that only the ranges 50 (covering 49.9 to 50.5 MHz) and 50.5 (covering 50.4 to 51.0 MHz) can be covered with crystals supplied. All other ranges require appropriate plug-in accessory crystals (see Section XII).

In the last counter-clockwise position of the RANGE switch (labeled "2 meters"), the 50 MHz section of the transceiver is disabled. 14 MHz VIF input and output jacks are provided for the R.L. Drake model SC-2 converter and 2 m-transverters.

6. PLATE - The PLATE control tunes the power amplifier pi-network circuit to resonance by varying the input capacity.
7. DRIVER TUNE - This control peaks the driver plate circuit coil.
8. LOAD - The LOAD control matches the impedance of the transceiver power amplifier to the impedance of the load by varying the output capacity of the pi-network circuit.
9. FILTER - The FILTER switch selects the upper or lower sideband filters for SSB, or the AM or CW filters.

Please note that only the USB filter is supplied with the unit. AM and CW transmitting and receiving can be done with this filter, although the accessory AM and CW filters provide bandwidths more adequate for receiving these modes. The LSB accessory plug-in filter is necessary for transmitting and receiving lower sideband signals.

10. AGC - The AGC switch allows you to change the release time constant of the receiving AGC (also called AVC). In the two counter-clockwise positions of this switch the noise blanker, if installed, is activated.
 11. OUTPUT METER CONTROL - This control consists of a push switch and potentiometer. Pushing in converts meter from plate amperes to a relative output indicator and rotating varies the sensitivity of this indicator.
 12. S-METER - The S-METER indicates relative signal strength of the received signal. It is calibrated in S-units from S-1 to S-9 and in dB over S-9. Each S-unit equals approximately 5 dB and S-9 equals about 10 microvolts. On transmit, it indicates the point at which the transmitting AGC starts, to help in setting the proper level of the XMTR GAIN control.
 13. PLATE AMPERES - The PLATE AMPERES meter indicates plate current in the final amplifier tubes, and relative RF output.
 14. PTO INDICATOR LAMP - The PTO INDICATOR LAMP (mounted directly above the main tuning knob) lights only while the TR-6 PTO is functioning. For example, when using the RV-6 with its function switch in "RVC" and transmitting with the TR-6, the indicator lamp lights on "transmit". The RV-6 indicator lamp lights whenever the TR-6 lamp does not.
- B. SIDE CONTROLS AND JACKS (front to rear)

1. PHONES - The headphone jack automatically disconnects the speaker when the headphones are plugged in. The audio output impedance at the jack is 4 ohms.

Headphones with any impedance may be used. Headphones with a medium impedance (like 500 ohm) will be found most suitable. A speaker may be plugged in here instead of connecting it to the power connector if so desired.

A Switchcraft type 229 plug (red) is supplied with the TR-6 which can be used either here or at the KEY jack.

2. MIC - This is a .210-inch diameter phone jack of the three conductor variety to accommodate microphones with push to talk switches. It requires a Switchcraft type S-230 plug which is supplied with your TR-6.
3. VOX - The VOX control adjusts the gain of the VOX amplifier, and relay release time on CW.
4. ANTI-VOX - The ANTI-VOX control adjusts the sensitivity of the ANTI-VOX system.
5. ZERO - The S-Meter ZERO control is provided for adjusting the no signal reading of the S-Meter to S-1.
6. KEY - The KEY jack is of the normally closed variety. The key, if plugged in, allows keyed CW operation (A-1).

Note that plugging a key into this jack will disable the transmitter on all modes and the receiver on AM unless the key is closed.

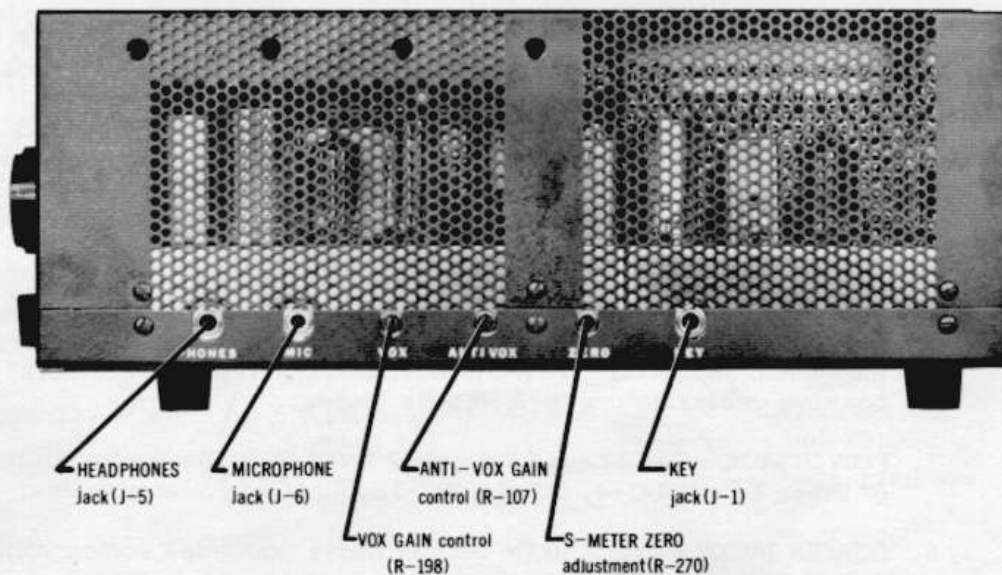

FIG.2 - SIDE VIEW

C. REAR CONTROLS AND JACKS

1. LIGHTS - The LIGHTS switch is a two position slide switch which is used to control the brilliance of the dial lights. The letters D and B indicate dim and bright respectively.
2. CARRIER BALANCE - The CARRIER BALANCE control is a potentiometer located on top of the chassis along the rear edge and is provided for balancing the balanced modulator.

Note that this control has a planetary drive and requires 10 1/4 turns for complete travel.

3. SIDETONE - The SIDETONE control, located on the rear of the chassis, controls the volume of the CW sidetone with respect to the received signal. If no sidetone is desired, rotate the SIDETONE control fully counter-clockwise.
4. MUTE - The MUTE jack provides a means of muting an external receiver without an external relay. It provides DC path to ground on receive and may be used with Drake 1-A, 2-A, 2-B, 2-C, R-4, R-4A, and R-4B receivers.
5. CONV JACK - The CONV JACK connects to the 14 MHz variable IF system of the TR-6. It permits the use of the TR-6 with an outboard receiver tuning from 13.9 to 14.5 MHz. This jack also permits reception with Drake SC-6 or SC-2 converters or other converters having a 13.9 to 14.5 MHz IF output. The TR-6 receiving converter may be disabled by placing the range switch in the "2 Meters" position. Otherwise two frequencies, possibly in different bands, may be monitored at the same time.
6. TRSV JACK - The TRSV JACK provides output for transverters requiring 13.9 to 14.5 MHz input. When using the TR-6 with a transverter, the RANGE switch on the TR-6 should be placed in the "2 Meters" position to disable the TR-6 50 MHz stages.
7. POWER JACK - The 12 position male POWER JACK fits the output plug of Drake DC-3, DC-4, DC-24, AC-3, and AC-4 power supplies.
8. SCREEN JACKS - The SCREEN JACK provides modulated screen voltage for transverters.

CAUTION: +250 volts DC is present on the center terminal of this jack.

9. GROUND - A stud is provided near the left edge of the rear of the TR-6 chassis for connecting the transceiver to ground, if available. Use a short, heavy wire. This stud must also be used for joining the TR-6 to the RV-6 chassis is used.
10. ANTENNA - An SO239 connector connects the TR-6 to the antenna system.

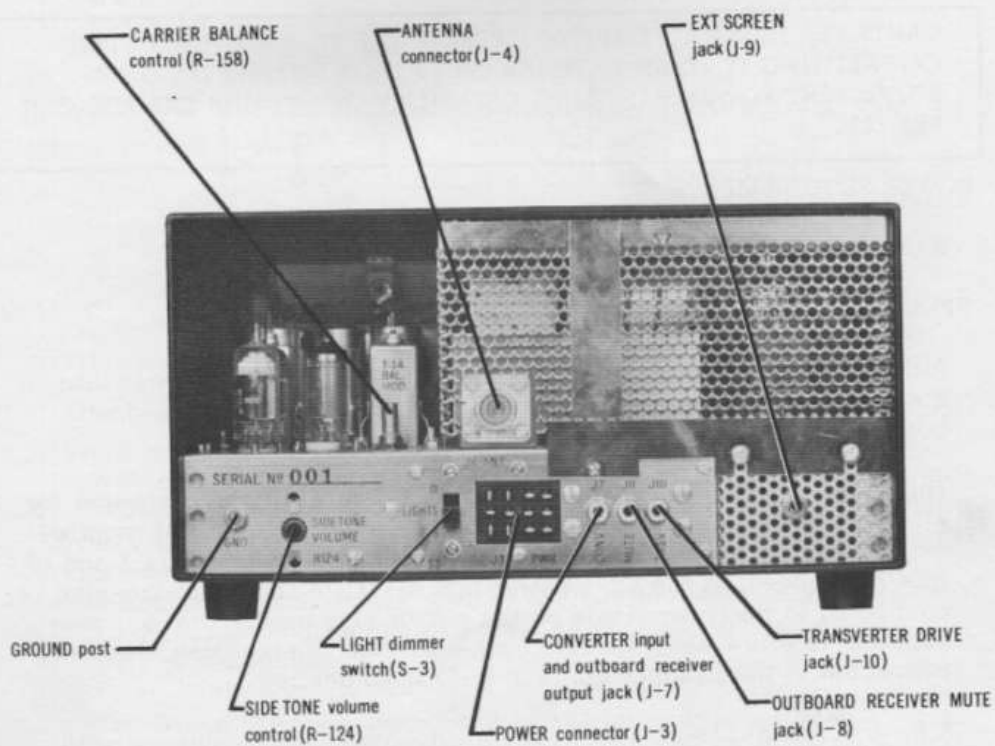

FIG.3 - REAR VIEW

V. INSTALLATION

A. ANTENNA REQUIREMENTS

The TR-6 is designed to work into RF loads with a nominal impedance of 50 ohms.

The SWR should not exceed 2:1 with respect to 50 ohms. For detailed discussions of antennas and feedlines, refer to a good VHF antenna manual.

Antenna connection to the TR-6 is provided at the SO-239 coax connector located on the rear of the shielded compartment housing the final amplifier components.

CAUTION: NEVER ATTEMPT TO OPERATE THE TR-6 WITHOUT FIRST CONNECTING IT TO AN ANTENNA OR 50 OHM DUMMY LOAD OF SUFFICIENT POWER HANDLING CAPABILITY OR SERIOUS DAMAGE CAN RESULT.

B. POWER REQUIREMENTS

Refer to section II, paragraph D, for power requirements.

C. SPEAKER AND HEADPHONES REQUIREMENTS

Although the TR-6 is designed to put out maximum audio power into a 4 ohm load, headphones with higher impedance may be used with good results.

The Drake model MS-4 speaker is designed as a matching speaker for all Drake receivers and transceivers and perfectly meets all requirements for TR-6 speakers. The speaker connects to terminals 7 and 12 (pin 7 grounded) of the TR-6 power jack (J-3). A female phone-plug is connected to these terminals on the output plug on the Drake power supplies to allow easy speaker hook-up. The speaker may also be connected to the headphones jack (J-5) if so desired.

A Switchcraft S-239 plug to fit the headphones jack is shipped with the TR-6.

D. KEY AND MICROPHONE REQUIREMENTS

1. KEY - The Switchcraft S-239 plug also fits the key jack (J-1). Key shaping and suppression networks in parallel with the key contacts

(as used on older keys made for cathode keying), must be removed. Electronic keyers must be connected for grid block keying.

2. MICROPHONE - The TR-6 is designed for use with a high-impedance, high-output microphone (ceramic or crystal).

A microphone with a wide and flat frequency response will enable you to obtain peak performance from your TR-6. For good VOX (voice control) operation, it is desirable for the mike to have a cardioid pattern to reduce pickup from the back and sides. This enables you to operate with higher receiver audio gain, giving better VOX operation and reducing echoes, reverberation, and noise pick-up in the fixed or mobile installation. Microphones with limited low or high frequency response and with peaks in the voice range should be avoided.

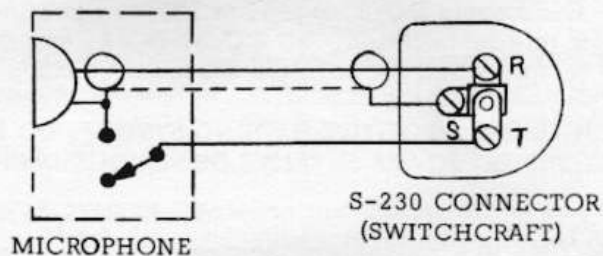

Fig. 4

A three conductor microphone plug (Switchcraft type S-230) is provided with the TR-6. The microphone must be connected as shown in fig. 4 for proper VOX and push-to-talk operation. Many microphones that are furnished with a switch are wired so that the microphone cartridge is open or short circuited unless the switch is depressed. This function must be defeated or VOX operation will be impossible.

The Drake 729 SRD microphone is available at a reasonable price and comes properly wired to the plug. It has a high impedance output and cardioid pattern.

E. LOCATION

In general, the location of the TR-6 is not critical, either in fixed or mobile installations. However, care should be taken to insure that space is allowed around the unit to allow adequate air circulation.

Extremely hot locations, such as near radiators or heating units, should be avoided. Do not cover the top of the TR-6 with books, papers, or pieces of equipment or overheating may result.

F. FIXED INSTALLATION

For fixed installation, our models AC-3 or AC-4 115/230 VAC 50/60 Hz power supplies will be required, and the model MS-4 matching speaker is highly desirable. Connect these units as shown in figure 7.

Note that the AC-4 power supply will fit inside the MS-4 cabinet to form one compact unit.

G. MOBILE INSTALLATION

The TR-6 may be installed in any vehicle having a 12 or 24 VDC electrical system. Our models DC-3, DC-4, or DC-24 power supplies will be required for this installation. All DC-3, DC-4, and DC-24 power supplies are factory wired for negative ground systems.

IF YOUR VEHICLE HAS A POSITIVE GROUND SYSTEM, DO NOT ATTEMPT TO CONNECT THE DC POWER SUPPLIES OR SERIOUS DAMAGE WILL RESULT.

1. Mount the TR-6 in a convenient location under the dash using the MMK-3 mobile mounting kit. See MMK-3 instruction sheet for more detailed instructions on various suggested mounting methods. Be sure to allow adequate clearance for air circulation and at the right side for access to the screw driver adjustments and the mike jack.
2. The recommended mounting position for the DC power supplies is on the passenger side of the firewall. We do not recommend that it be placed in the trunk due to the excessive primary lead length or in the engine compartment unless it is protected from water and engine heat.

Make sure that the on-off switch on the TR-6 is in the off position (audio gain fully counter-clockwise until a click is heard), and connect the female power connector on the end of the power cable to the TR-6. Coil up excess cable and tape in an out-of-the-way location. You may need the extra length when you trade cars. Run the black wire from the power supply to a convenient ground and run the red wire through the firewall to the battery terminal of the starter relay. Shorten the heavy red and black wires as much as possible.

3. Install a mobile antenna in the manner recommended by the antenna manufacturer and connect the coax lead from it to the SO-239 connector of the TR-6 (see figure 6). The use of a directional RF wattmeter, Drake W-4 or WV-4, is recommended.
4. If your car has a transistor radio, we suggest you install a separate speaker for use with the TR-6. However, if the radio in your car has a vacuum tube audio amplifier, and if one side of its speaker is grounded, run a wire from the ungrounded terminal to the center conductor of a male phone plug. Insert this plug in the female jack molded into the end of the 6 inch wire protruding from the connector on the end of the DC-4 power cable. It should be unnecessary to disconnect the auto radio output transformer when the TR-6 is used, unless it has insufficient volume. If this proves to be the case, a SPDT switch can be installed so that the speaker lead goes to the pole, the car radio output goes to one contact, and the TR-6 output goes to the remaining contact.
5. For information on noise suppression, consult the mobile noise suppression section of the ARRL Radio Amateur's Handbook.

H. INSTALLATION WITH OTHER ACCESSORIES

1. LINEAR AMPLIFIER - Refer to the manual of the amplifier in use. If the amplifier has AGC output (sometimes called ALC), it should be connected to pin 3 of the power jack (J-3) of the TR-6. The use of shielded wire is recommended. The AC-4 power supply has an AGC jack installed for this purpose.
2. REMOTE VFO - The cable from the RV-6 connects to J-2 of the TR-6. Refer to the instruction sheet of the RV-6.
3. CRYSTAL CONTROL UNIT - The FF-1 plugs into the RV-6 socket of the TR-6. Refer to the FF-1 instruction sheet.
4. TRANSMITTING AND RECEIVING CONVERTERS - IF input and output jacks as well as a screen supply output for transverters are provided in the rear of the TR-6. For hook-up, refer to the respective manuals.
5. NOISE BLANKER - A socket (J-11) for plugging in the cable coming from a noise blanker is located in top of the TR-6 chassis. Save the dummy plug that is plugged into J-11. For installation of the noise blanker, follow the instructions that are included with the unit.

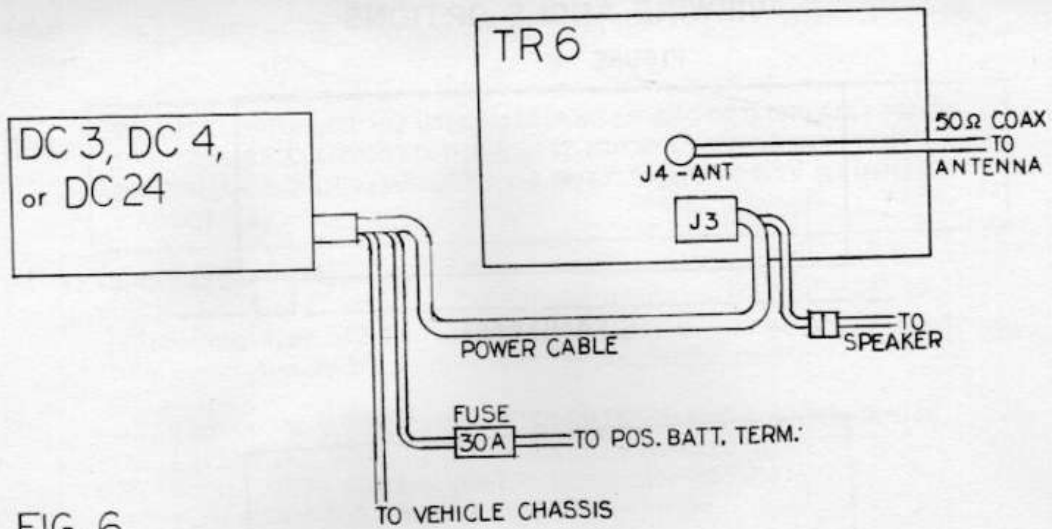

FIG. 6
MOBILE INSTALLATION OF TR 6

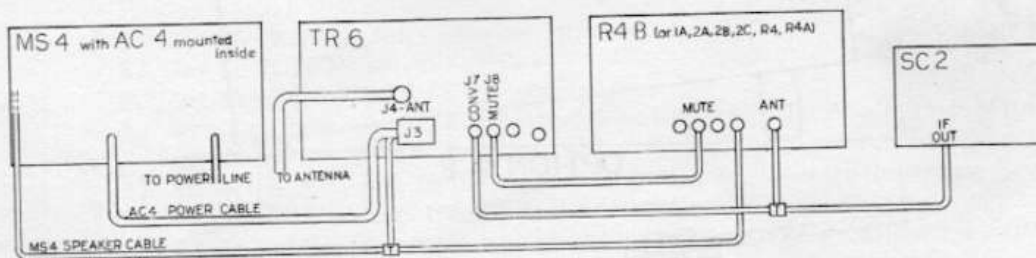
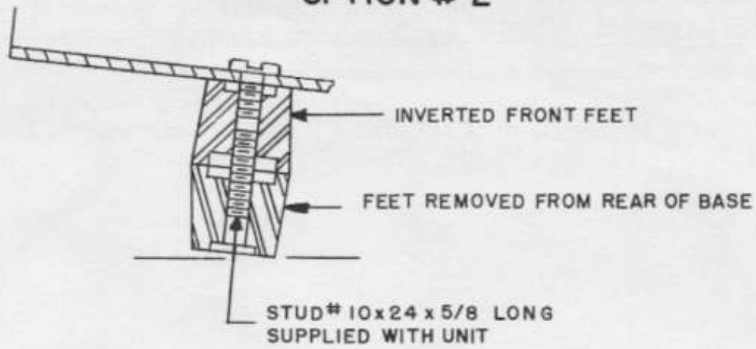
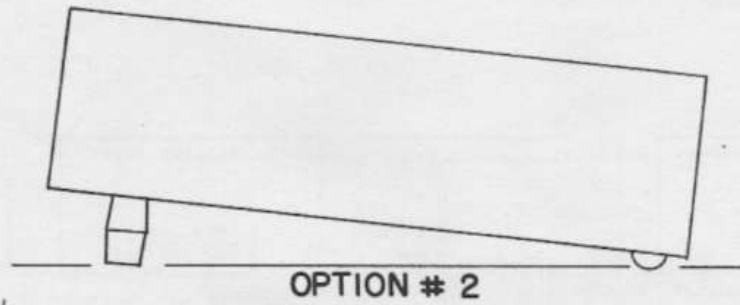
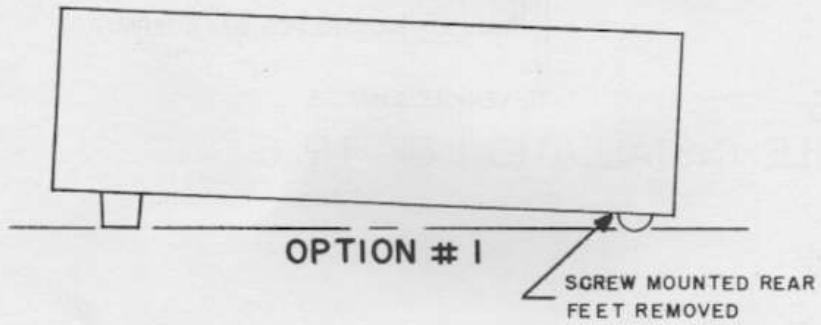
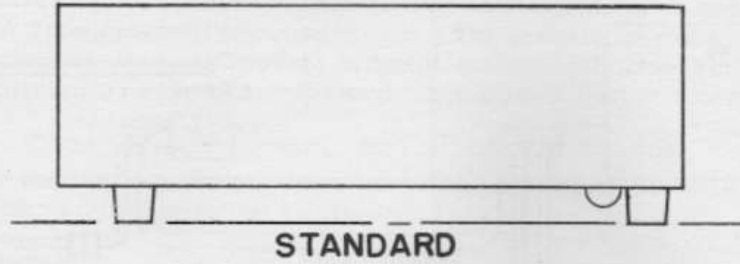

FIG. 7-CONNECTION OF TR 6 WITH AC 4, MS 4, SC 2, AND AN EXTERNAL RECEIVER

VIEWING ANGLE OPTIONS

FIGURE 8



VI. TUNING PROCEDURE

WARNING: UNDER NO CIRCUMSTANCES SHOULD OPERATION OF THE TR-6 BE ATTEMPTED UNLESS IT IS CONNECTED TO PROPER ANTENNA OR A DUMMY LOAD OF SUFFICIENT POWER HANDLING CAPABILITY.

A. BIAS ADJUSTMENT

Before any type of operation is attempted, it will be necessary to set the power supply bias adjustment as described here.

1. Turn on TR-6 by rotating RCVR GAIN control knob clockwise.
2. Let the unit warm up for at least 15 minutes.
3. Rotate XMTR GAIN control fully counter-clockwise.
4. Turn SIDEBAND switch to the LSB position.
5. Turn function switch to CW.
6. Adjust the bias adjustment on the power supply for a reading of .1 on the plate amperes meter. This completes the adjustment.

B. ADJUSTING DIAL CALIBRATION

The calibration of the main tuning dial on the TR-6 may vary slightly from range to range due to the tolerance limits of the various crystals. Therefore, the main tuning dial index has been made adjustable by means of the small red knob to its right. To set the calibration on a given band, proceed as follows:

1. Set XMTR GAIN fully counter-clockwise.
2. Set FUNCTION switch to CAL.
3. Set RANGE SWITCH to desired range.
4. Zero beat the 100 KC calibrator signal nearest the desired operating frequency.
5. Slide the red knob to the right of the dial scale until the index line coincides with the 100 KC dial calibration.
6. While holding the main tuning knob, push in on its calibrated skirt and rotate it until the zero coincides with the indicator line.

C. TUNE-UP ON THE DESIRED RANGE

The CW position of the function switch is used for tuning up the transmitter. The key jack is a closed circuit type jack so it is not necessary to plug in a key for tune up.

WARNING: DO NOT ALLOW THE PLATE CURRENT TO EXCEED .1 AMPS FOR MORE THAN 5 OR 6 SECONDS IF THE PLATE CONTROL IS NOT TUNED FOR PLATE CURRENT DIP OR MAXIMUM R.F. OUTPUT. Failure to observe this warning will result in rapid final amplifier tube deterioration due to excessive plate dissipation.

Note that the final amplifier pi-network will match a 50 ohm load with VSWR no higher than 2:1. It may be found necessary to use an external antenna tuning network or change the feed line by 1/8 to 1/4 wave length to get the proper match.

1. Preset the controls as follows:

RANGE SWITCH to desired range.
FREQUENCY knob to or near frequency desired.
XMTR GAIN fully counter-clockwise.
LOAD to "4".
FILTER to USB.
FUNCTION switch on SSB.
DRIVER TUNE to "5".

2. Rotate the function switch to the CW position and advance the XMTR GAIN control clockwise until the plate amperes meter moves up scale slightly from idling current. (If plate current is high even with XMTR GAIN fully counter-clockwise, reduce it to idling by adjusting CARRIER BALANCE control (see section D), after the tune-up has been performed.
3. Depress the OUTPUT METER CONTROL and rotate it for a significant indication on the plate amperes meter. (This control converts the plate amperes meter to a relative output indicator and varies its sensitivity.) Tune the PLATE control for maximum RF output. Peak the DRIVER TUNE control for maximum RF output.
4. Rotate the XMTR GAIN control clockwise until plate current no longer increases. (This point should be found well before the knob reaches the 12 o'clock position.)

Alternately adjust LOAD and PLATE controls in small increments for maximum RF output. If meter goes off scale during this process, simply reduce its sensitivity by turning the output meter control counter-clockwise.

At this point, the plate current should read between .350 and .500 amps depending upon supply voltage, antenna match, drive, tube condition, etc. Do not attempt to increase the LOAD control beyond the point at which maximum RF output occurs or excessive plate dissipation will result.

It should not be necessary to advance the LOAD control beyond 7-1/2 to obtain maximum RF output. Further advancement indicates that the SWR of the antenna system is too high and leaving the control set beyond this point is likely to result in excessive harmonic radiation.

The above procedure should be completed as quickly as possible and the function switch should be returned to the SSB position.

D. ADJUSTMENT OF CARRIER BALANCE CONTROL

The CARRIER BALANCE control is factory adjusted and should not require resetting under most conditions. However, it should be checked before the TR-6 is operated on SSB.

The carrier suppression provided by the crystal filters on SSB is sufficiently great that it will be impossible to adjust the balanced modulator for optimum attenuation in this mode unless a sensitive RF detector (receiver) is used in close proximity to the transceiver. We therefore recommend that balanced modulator adjustment be performed in the CW mode since the filters are not effective here. The balanced modulator should be adjusted after the unit has warmed up for about 1/2 hour in order to maintain optimum balance over a prolonged period of time.

After tuning up the TR-6 as described above, set the filter switch to "USB", the XMTR GAIN fully counter-clockwise, and the FUNCTION switch to CW. Now depress OUTPUT METER CONTROL and adjust the CARRIER BALANCE control (located on top of the chassis near the rear edge) for zero RF output. If output cannot be reduced to zero, adjustment of the carrier balance capacitor may be necessary, (see section X). Return the FUNCTION switch to SSB. This completes the adjustment.

Some residual signal will occasionally be observed on the CW mode when the XMTR GAIN control is set at minimum. This is of no consequence since the additional attenuation provided by the filters on SSB will provide the desired carrier suppression.

VII. OPERATION

In the following discussion, it is assumed that the TR-6 has already been tuned up on or near the desired frequency as described under tuning procedures.

A. VOICE CONTROLLED OPERATION ON SSB

Preset the controls as follows:

FILTER on USB (or LSB if the lower sideband is desired and the LSB filter has been installed).
FUNCTION SWITCH on SSB.
XMTR GAIN fully counter-clockwise.
RF GAIN fully clockwise.
AF GAIN fully counter-clockwise (do not turn off power).
VOX GAIN fully clockwise.
ANTI VOX fully counter-clockwise.

While talking into the microphone in a normal voice, increase the XMTR GAIN control until the S-meter starts kicking up scale about 2 or 3 S-units above its resting value. (With no modulation, the S-meter will rest from about S-5 to S-9 on transmit.) This indicates that the transmitting AGC is starting to work and the transmitter is peaking at maximum output. Continue talking and reduce the VOX GAIN until a point is reached where further reduction results in too frequent relay drop-out.

Now increase the AF GAIN until received signals are of the desired volume. This may cause the transceiver to cycle back and forth between transmit and receive. Adjust the ANTI VOX control until this cycling stops. You are now ready to operate.

B. PUSH TO TALK OPERATION ON SSB

If the push to talk switch on your microphone is properly connected as described in section V, D, it may be depressed at any time, thus over-riding the VOX system.

If you do not desire the VOX to function at all, turn the VOX gain control fully counter-clockwise.

REMEMBER: On SSB, the TR-6 transmits on exactly the same frequency on which it receives. Therefore, be sure that before you answer another station's CQ, or break another QSO, you have the signals tuned in so that the voices sound normal. Otherwise, you will not be transmitting exactly on frequency.

Note if a key is used, it must either be closed or unplugged from the key jack for SSB and AM operation.

C. CW OPERATION

To work CW, plug your key into the KEY jack. If an electronic keyer is used, connect it for grid block keying. Leave the key in the open condition.

Note that the TR-6 uses shifted carrier CW. With this system, it is possible to transmit approximately on the received station's frequency without being zero beat while receiving. The receiver BFO is shifted from the transmitted signal frequency about 1 KHz.

To receive CW signals, place the function switch on the CW position and the filter switch in the USB position (CW position if a CW filter has been installed). Tune in a CW signal for an audio pitch of about 1 KHz and adjust the audio gain control for pleasing volume.

To transmit, depress the key, and rotate the XMTR GAIN control clockwise just below the point at which plate current no longer increases. DO NOT ADVANCE IT BEYOND THIS POINT.

Advance the SIDETONE control on the rear of the chassis until the sidetone reaches the desired volume. (Adjusting the RCVR GAIN knob will regulate both the received signal and sidetone volume.)

The TR-6 uses automatic transmit/receive switching. This means it will automatically transmit when the key is depressed and will remain in the transmit condition through keying. It will return to the receive condition when the key is released for a brief period. If this period is too long, decrease the VOX gain control to minimum.

If the relay fails to close when the function switch is placed in the CW position and the key, if used is closed, the VOX gain control should be advanced until positive relay action is obtained.

Manual transmit receive switching can be accomplished by connecting an external switch (e.g. foot switch) to the push to talk circuit of the MIC jack.

D. AM OPERATION

For AM operation, the FUNCTION switch should be in the AM position and the filter switch should be in the USB position (AM position if an AM filter has been installed). If a key is used, it should be left closed or unplugged.

Tune in the AM signals for most pleasing audio. With the USB filter this will not necessarily coincide with maximum S-meter reading.

The same procedure should be followed in setting the various gain controls for VOX operation on AM as for SSB, except that the XMTR GAIN should be adjusted for plate current peaks of from .2 to .25 amps when talking into the microphone in a normal voice. Care should be taken to stay within these limits since the transmitting AGC does not work on AM.

The TR-6 uses a controlled carrier screen modulator which holds the unmodulated carrier input power to a few watts but allows 300 watts P.E.P. input on voice peaks. This system is compatible with SSB linear amplifiers. Due to the low duty cycle of this type of AM, a linear can be run with the same P.E.P. input as it can on SSB.

E. GENERAL PRECAUTIONS FOR OPERATION NEAR BAND EDGE

If you intend to operate near the edge of a band, be sure that you check the dial calibration as described under tuning procedure. When working SSB be sure you are using the sideband that will be inside the band. On AM or CW, the transmitted carrier will be 1 KHz higher than the indicated dial frequency.

F. OPERATION WITH LINEAR AMPLIFIERS

The TR-6 transceiver is conservatively rated at 300 watts PEP input. It is doubtful if it would be worthwhile to use a linear with power rating of less than 1000 watts PEP input. A triode type grounded grid linear of 1000 to 2000 watt PEP rating will present a satisfactory load for the TR-6.

If your particular linear is of the grounded cathode type with high impedance input, it will be necessary to install a resistive pad between the TR-6 and the linear that will present the proper impedance to the TR-6. Such a pad must be made of non-inductive resistors and must have adequate power handling capacity to prevent it from being destroyed when the TR-6 is turned on. Antenna switching should be accomplished as shown in Figure 5. Many linears have these relays built in.

In order to properly operate the TR-6 with a linear, proceed as follows:

1. With the TR-6 connected to the linear, perform a tune-up as described in paragraph C of section VI.

2. Switch the FUNCTION switch to the desired mode of operation.
3. Set the XMTR GAIN control until the desired amount of input to the linear amplifier is obtained.

Note that when the TR-6 is loaded much below maximum RF output, the AGC does not function properly and flat topping in the TR-6 may result. Care should be taken to keep the XMTR GAIN below the point where this occurs. This can be accomplished by making sure that the average peak plate current does not exceed one third of the plate current obtained on tune-up (step 4).

If your linear amplifier has AGC output, connect it to the TR-6 as shown in figure 5. If the TR-6 is properly tuned, this should prevent flat topping on SSB regardless of the XMTR GAIN control setting. However, it will not prevent overdrive on AM since the AGC does not function in this mode.

G. RTTY OPERATION

The TR-6 is capable of RTTY communications in the AFSK as well as in the RFSK mode. AFSK communications can be achieved by switching the TR-6 function switch to AM and feeding the audio signal into the microphone jack of the TR-6. Switching the TR-6 function switch to the SSB mode under these same conditions will result in simulated RFSK emission.

If RTTY operation using true RFSK is contemplated, write for special instructions.

VIII. THEORY OF OPERATION

A. RECEIVER CIRCUITRY

A signal entering the TR-6 through the antenna jack (J-4) is applied to a tuned 6 meter circuit formed by L-10 and associated circuit and stray capacity.

L-10 also performs an impedance transformation from the 50 ohm line to the input of the receiving RF amplifier, Q-11.

After amplification in Q-11, Q-12, the signal goes through a 49.4 to 54.0 MHz bandpass formed by T-17, L-15, and their associated capacities.

The signal then is mixed in Q-13 with an appropriate crystal controlled frequency to a range of 13.9 to 14.5 MHz. The injection signal is obtained from a switchable crystal oscillator (Q-7), through a buffer (Q-9).

After passing through a 13.9 to 14.5 MHz bandpass formed by L-14, T-18, C-209, C-223, C-191, C-224, the signal is mixed in V-3 with a signal of a frequency variable between 4.9 and 5.5 MHz to obtain the fixed IF frequency of 9 MHz.

The variable frequency is obtained from the VFO formed by Q-1, Q-2, and associated circuitry.

The signal then passes through the IF crystal filter and is amplified in V-11 and V-12 and is coupled to the AVC amplifier and detector system.

V-13a serves as an AVC amplifier, the AVC voltage developed on the plate of that tube controls the bias and thereby the gain of Q-12, V-3, V-11, and V-12.

V-16 serves as the BFO and product detector. The audio signal is then amplified in V-17 to speaker level.

On AM the diode section of V-2 serves as an envelope detector, and the triode section serves as an audio amplifier. On CW the triode section is converted into an audio generator to generate the sidetone signal. The audio signal from V-2 then passes on to V-17 for final amplification.

B. TRANSMITTER CIRCUITRY

The IF carrier is generated in a crystal oscillator formed by V-16. After passing through the balanced modulator (D-11 through D-14), the signal is amplified in V-15 and then passed through the IF crystal filter.

The signal is then passed to V-7 where it is mixed with the VFO frequency to give the VIF 13.9 to 14.5 MHz.

After passing through the VIF bandpass formed by T-10, C-291, and C-292, the signal is fed to V-4 where it is mixed with a signal from the switchable crystal oscillator to give the desired output frequency. The signal is then amplified in V-6, V-8, V-9, and V-10 and is connected to the antenna jack (J-4) through a pi-network consisting of C-294, L-19, and C-293.

In the sideband mode, the audio signal from the microphone is amplified in V-18, and then mixed with the IF carrier in the balanced modulator, to give a double sideband, suppressed carrier signal. It is then processed as described above.

In the CW mode the modulator is unbalanced by means of a variable DC voltage (variable through R-100) to give an output on the carrier frequency. The keying is accomplished by keying the bias on V-7.

In the AM mode the balanced modulator is unbalanced with a fixed DC voltage. The modulation takes place as a controlled carrier screen modulation of the RF final amplifier tubes (V-8, V-9, V-10). The audio signal path is: From the microphone through the microphone amplifier (V-18) to the AM modulator (V-14) and from there to the final amplifier tube screens grids.

The transmitting AGC is generated in V-13b. The plate of this tube goes negative at the threshold of grid current in the final tubes (SSB mode only). This negative voltage reduces the gain of V-15, thus preventing any excessive amount of grid current in the final tubes which could cause flat topping.

Transistor Q-10 serves as a buffer for the transmitting VIF output.

C. TRANSCEIVING CIRCUITRY

Transmit-receive switching is accomplished by means of relay K-1. One set of DT contacts accomplishes the antenna switching from the transmitting to the receiving section, whereas the other set grounds the cathodes of those tubes used only for transmitting or receiving, respectively,

thus activating the respective sections of the transceiver.

Transistor Q-5 accomplishes the T/R switching of the receiver's front-end field effect transistors Q-11 and Q-13 by ground their sources.

The relay is activated by tube V-19, which is triggered by a signal from the microphone amplifier (V-18), a signal from the sidetone generator (CW only), or the closing of a PTT contact. The ANTI-VOX signal coming from tube V-17 is also fed to V-19.

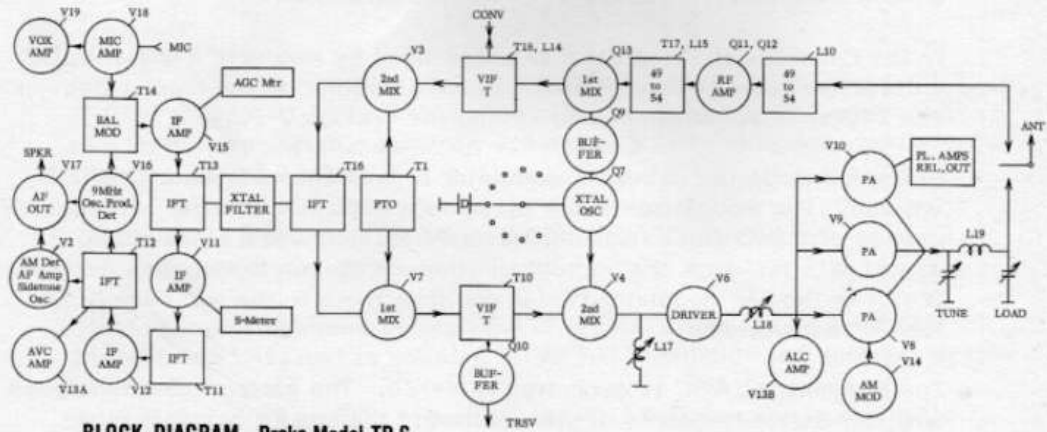

BLOCK DIAGRAM - Drake Model TR-6