



ANTENNA TUNER

Model **AT-230**

INSTRUCTION MANUAL

We are happy you have chosen the Model AT-230 for your antenna tuning needs. The AT-230 has been designed with the quality and performance that makes Kenwood "The pacesetter in Amateur radio".

FEATURES

1. Your AT-230 is an antenna tuner designed for use with the Kenwood HF transceiver.
2. The AT-230 consists of an adjustable antenna coupler, a through-line RF wattmeter, an SWR meter and an antenna switch.
3. The AT-230 is designed to be used on all amateur bands between 1.8MHz and 30MHz.
4. The RF wattmeter has two ranges, 20W and 200W.
5. The antenna switch has four outputs. Two of these are for coaxial fed antennas, one is for a wire antenna and one is for connection to a dummy load.
6. The antenna matching circuit is effective in reducing TVI as it acts as a band-pass filter.
7. Your AT-230 is also capable of matching your transceiver with a wire antenna such as an inverted-L. Therefore it is possible to enjoy communication on the lower frequency bands.

CONTENTS

AT-230 SPECIFICATIONS	3
SECTION 1. PREPARATION FOR USE	4
SECTION 2. CONTROLS AND THEIR FUNCTION	5
SECTION 3. OPERATION	7
SECTION 4. CIRCUIT DESCRIPTION	9
SECTION 5. ADJUSTMENT AND MAINTENANCE	10
SCHEMATIC DIAGRAM	11

AT-230 SPECIFICATIONS

1. Antenna Coupler

Frequency range:	9 amateur bands from 1.8 to 29.7 MHz.
Input impedance:	50 Ω
Output impedance:	10 to 500 Ω , unbalanced.
Through power:	200 W at max.
Insertion loss:	Less than 0.5 dB at optimum match
PROVISO:	1.8 MHz only
Output impedance:	20 to 500 Ω , unbalanced
Through power:	100 W at max.

2. Wattmeter

Type:	Through-line wattmeter.
Frequency range:	1.8 to 30 MHz.
Measurable RF power:	Up to 20/200 W, switched.
Measurement mode:	Forward or reflected power switched.
Impedance:	50 Ω
Accuracy:	Better than $\pm 10\%$ of full scale.

3. SWR Meter

SWR detection:	Toroidal core direction coupler.
Measurable range:	1.1 to 10.
Min. power required:	4 W.

4. General

Connectors, INPUT:	UHF type, 50 Ω
Connectors, ANT-1:	UHF type.
ANT-2:	UHF type.
ANT-3:	Wire antenna only.
GND:	Stud for grounding
Dimensions:	H 133 mm (5-1/4") W 180 mm (7-1/16") D 287 mm (11-5/16")
Net weight:	3.4 kg (7.5 lbs) approx.

Note: Circuit and ratings are subject to change without notice due to developments in technology.

SECTION 1. PREPARATION FOR USE

1.1 Accessories

Carefully unpack your AT-230 Antenna Tuner and verify inclusion of these supplied accessories:

- * Operating manual 1 copy
- * Extension foot (J02-0049-04) . . . 2 pieces
- * Rubber sleeve (F09-0402-05) . . . 1 piece
- * Screws, (4mm diameter)N. 2 pieces
- * Terminal (E23-0408-05) 2 pieces

1-2 Interconnection Cable

To connect your AT-230 with the KENWOOD HF transceiver, an interconnection cable is required. Refer to Figure 1-1 for details.

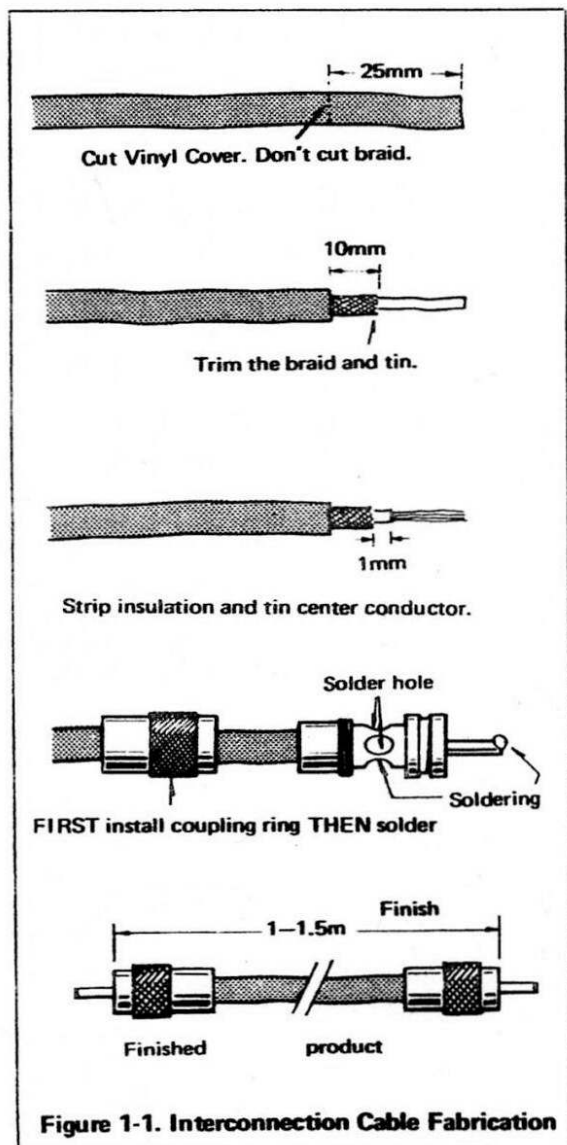

1.3 Using A Dummy Load

An all solid-state transceiver, doesn't usually require a dummy load since no tuning is required. Tuning tube power amplifiers, or performing service or checkouts requires a dummy load. You may fabricate a load by referring to figure 1-2. A 100 watt dummy load may be constructed with twenty $1k\Omega/5W$ or $10W$ metal-film resistors in parallel.

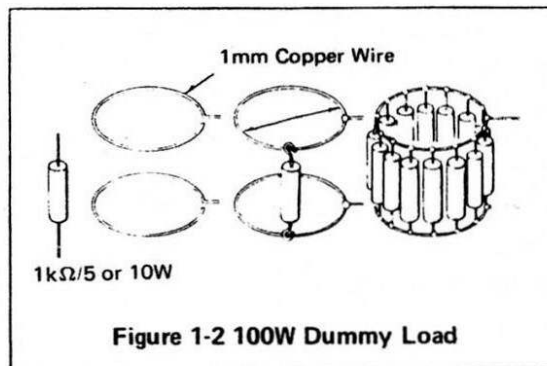

SECTION 2. CONTROLS AND THEIR FUNCTION

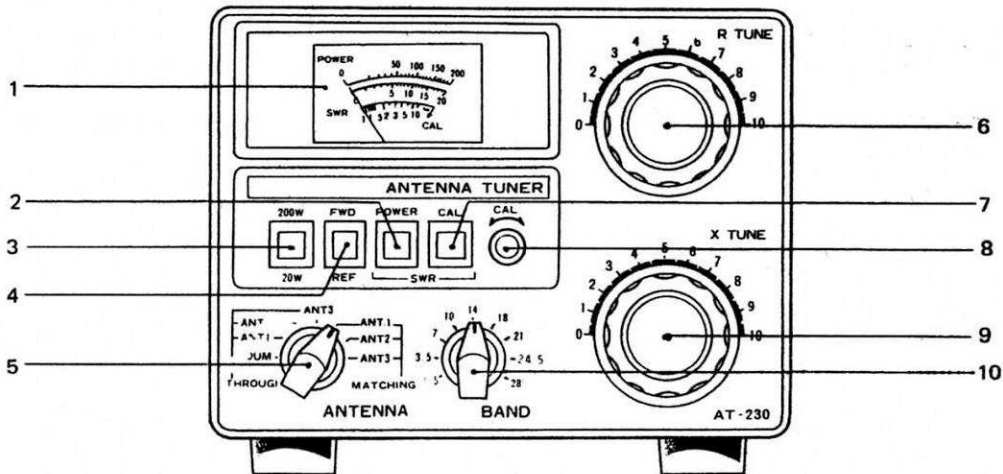

Figure 2-1. Front View

1. Meter

The meter reads SWR (standing-wave ratio) or transmit power on the 200W or 20W scales.

2. POWER-SWR (Wattmeter-SWR Selector) Switch

The POWER-SWR switch selects meter function; wattmeter in the POWER position and SWR meter in the SWR position.

3. Wattmeter Range Selector Switch

This switch selects the full scale wattmeter range, 20W or 200W. Set the switch to the 200W position for 100W transceivers.

4. FWR-REF (Forward-Reflected Power Selector) Switch

The FWD-REF switch allows the Wattmeter to read either forward or reflected power. The effective radiated power can be computed by subtracting the reflected power from the forward power.

5. ANT (Antenna Selector) Switch

Your AT-230 can switch three antennas and a dummy load as the load to the transmitter. At the "THROUGH" position each antenna can be connected directly to the transceiver. Output power and SWR can be measured at either the through or matching position.

6. R TUNE

This adjusts the resistance component of the antenna.

7. CAL (Calibrate) Switch

For measuring SWR, this switch is first set to the CAL position, this switch is advanced until the meter pointer swings to the CAL position. Then set to the SWR position and read SWR.

8. CAL (Calibrate) Control

To measure SWR, adjust this control to calibrate the meter. (Adjust as described in item 5.)

9. X TUNE Control

This adjusts the reactance component of the antenna.

CAUTION: DO NOT operate the band switch while transmitting.
Equipment damage WILL occur.

10. BAND Switch (Tapped Inductor)

Initially set this switch to the band you will operate.

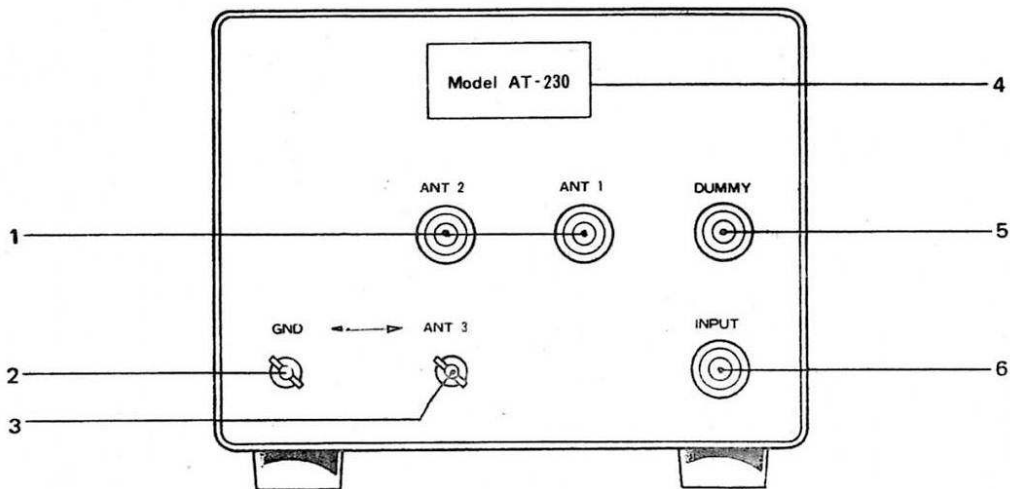

Fig. 2-2. Rear View

1. ANT-1 and ANT-2 Connectors

These UHF-type connectors are provided for conventional COAX-Fed antennas.

2. GND stud

ALWAYS connect the AT-230 to a **GOOD EARTH GROUND**. Use a ground rod and a short run of heavy ground lead or ground braid. Do not use housewiring as ground.

NOTE: DC ground is not necessarily RF ground.

3. ANT-3 Connector

This connector is provided for use with a wire-type antenna (for typical example, an inverted-L).

4. Serial No. Plate

This plate is stamped with the Serial Number of your unit. (Please record this number on the back cover of the book).

5. DUMMY Load Connector

Connect a dummy load for adjusting the transceiver. Note that this connector is not fed through the antenna coupler.

6. INPUT Connector

Connect your XMTR or XCVR to this terminal.

SECTION 3. OPERATION

Interconnect the AT-230 with your transceiver, antenna and dummy load as illustrated in Figure 3-1.

Adjusting the transceiver

When the TS-830S is used,

- A. Set the ANT switch to the DUM position as shown in Figure 3-2.
- B. Adjust the transceiver for maximum output at your transmit frequency.

CAUTION: After set-up, do not move the transmitter controls unless changing band frequency.

Measuring the antenna system SWR

Before adjusting the antenna coupler, you should know the antenna system SWR.

- a. Set the controls as illustrated in Figure 3-3. Set the ANT switch to the "THROUGH" position to which the desired antenna is connected.
- b. With a minimum of transmit power, adjust the CAL control so the meter pointer deflects to

the CAL mark.

- c. Place the CAL-SWR switch to the SWR position. Now, you are reading SWR. If the SWR is lower than 1.5:1, the antenna system is sufficiently matched for practical use. If not, you should tune it,

NOTE: In event of very high SWR (over 10:1), check the antenna and feed system for breaks or short circuit.

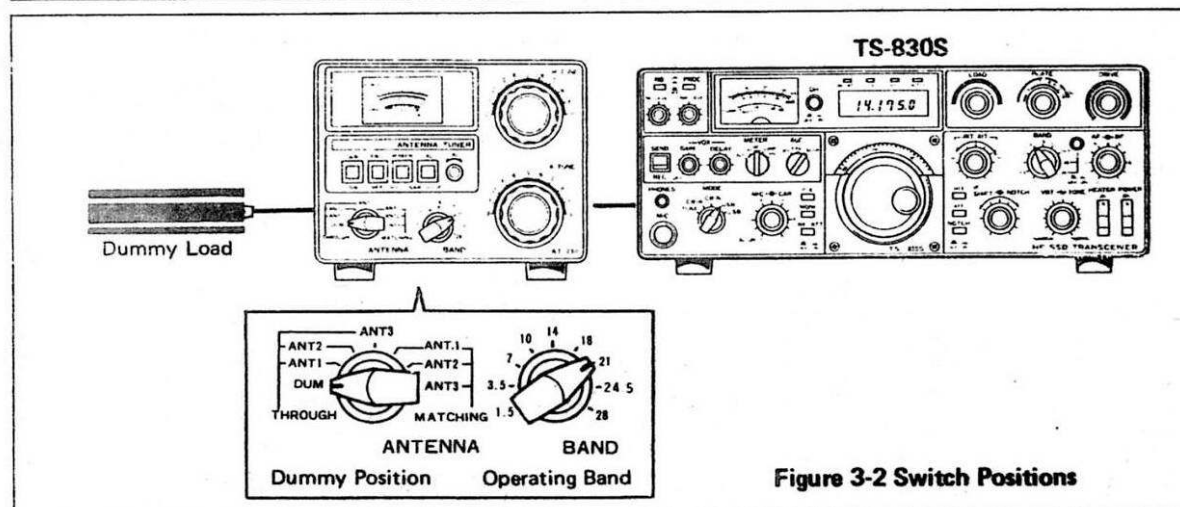
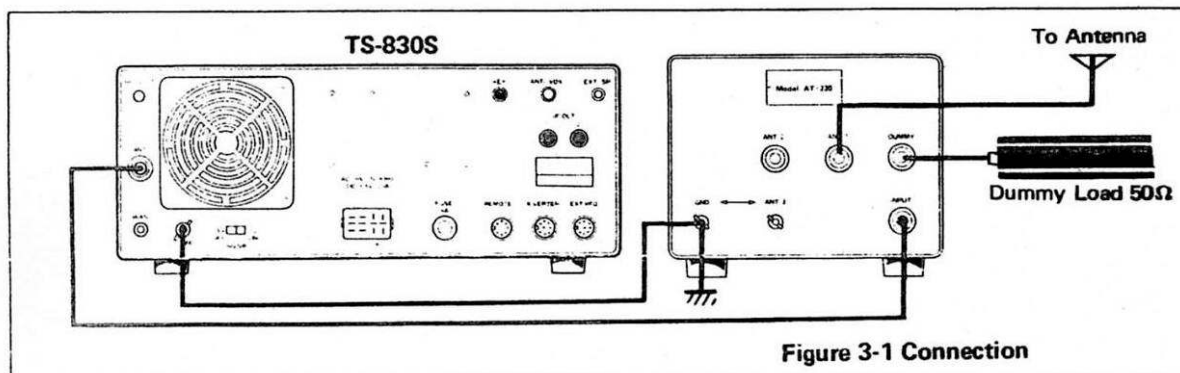
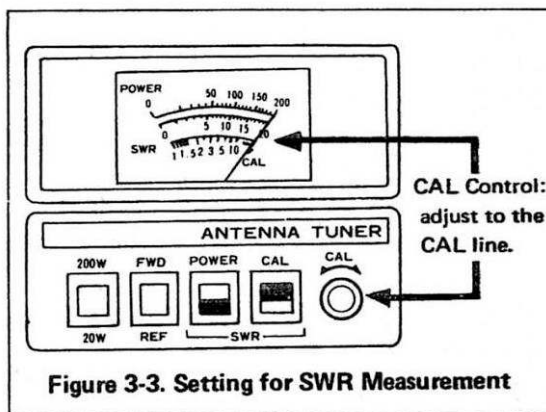

Adjusting the antenna coupler

The antenna coupler is used to match an antenna system if its SWR is too high.

- Initially, set the BAND switch to the operating band as shown in Figure 3-4.
- Set the ANT switch to the antenna to be matched.
- Turn the FWD-REF switch to the REF position.
- You will first measure the reflected power. (alternately) Adjust the R TUNE and X TUNE controls for minimum meter deflection. Reflected power will be close to zero at match.

NOTE: To achieve a better match, you may sometimes select another bandswitch position on the tapped inductor. Unkey the transmitter before changing the bandswitch setting, always tune and measure at the lowest output level possible.

Table 3-1 shows initial control positions for coupler adjustment.

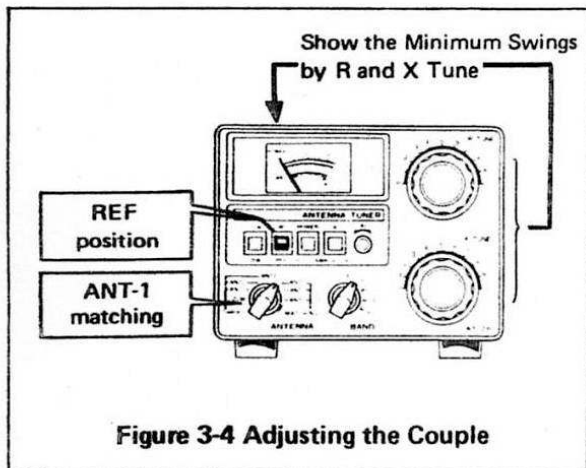

Figure 3-4 Adjusting the Coupler

Table 3-1 Initial Control Settings at 50Ω

MHz	R TUNE	X TUNE
1.80	5.0	4.6
3.80	6.2	6.3
7.00	6.2	7.0
10.10	7.3	7.3
14.00	7.2	8.0
18.10	8.3	8.4
21.00	8.2	8.7
24.90	8.6	8.7
28.50	9.0	9.0

Remarks: Values are approximate.

Measuring SWR when using the coupler

After completion of coupler adjustments, you may measure the transmitter and antenna match in a manner similar to get daker bed in "Measuring the antenna system SWR".

Measuring Transmit Power

Set the switches as shown in Figure 3-5. You will measure forward power with the FWD-REF switch in the FWD position. Measure reflected power in the REF position.

NOTE: If SWR is excessive, measured power will be in error.

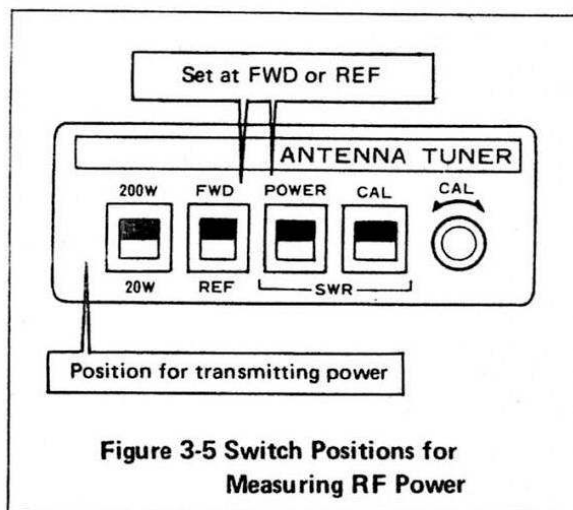

Figure 3-5 Switch Positions for Measuring RF Power

How to Use Your Antenna Coupler Correctly

This antenna coupler will be a useful addition to your station if it is used properly. There are some instances where an antenna coupler is not needed. The typical SWR curve of a multi-band Yagi is shown in Figure 3-6. (You should note that the SWR may change, depending on the antenna height and surrounding environment such as trees and buildings.) The curve shows that you do not need to use the antenna coupler in the 14.18 to 14.30 MHz range as the SWR is below 1.5:1. If the antenna coupler is used, the 0.3 db insertion loss will be greater than the improved power transfer obtained by using the antenna coupler. However, the antenna coupler will be effective in the CW band. The antenna coupler may be switched in or out by putting the ANT switch in the THROUGH or MATCHING ranges.

HOW TO USE WIRE ANTENNA CORRECTLY (Fig. 3-7)

Your AT-230 has a connector provided specifically for a wire antenna, so that you can enjoy communication with a simple antenna.

Good grounding of your AT-230 is essential for use with a wire antenna. For grounding, use metal ground rods specifically available for this application. For a simple ground, a lead water line can be tried. However, recently installed water pipes are made of polyvinyl instead of metal.

WARNING

Never use gas lines in any way for grounding, it is dangerous.

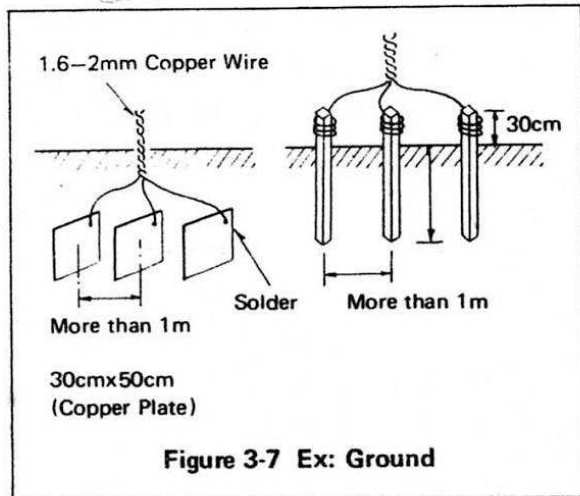
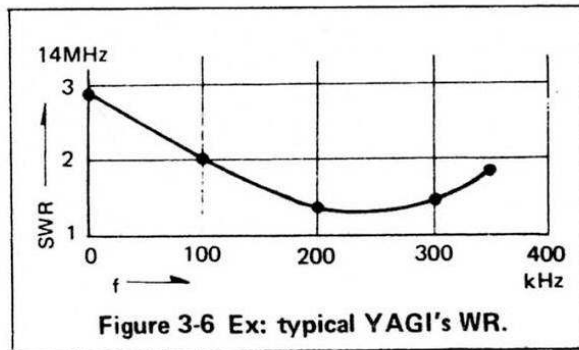

CAUTION

1. The ANT 3 terminal should be insulated by the rubber sleeve, as illustrated. It is provided to protect from high RF voltage.
2. Tuner and transceiver GND terminals should be wired together, and the tuner should be wired directly to earth ground.

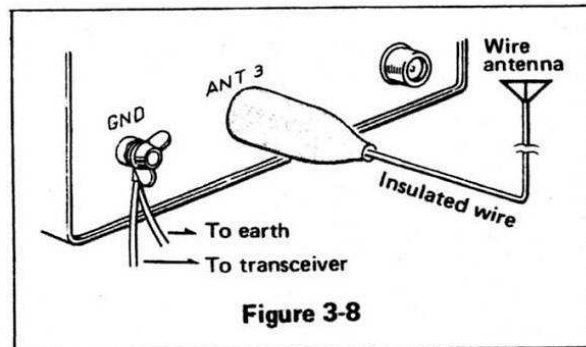
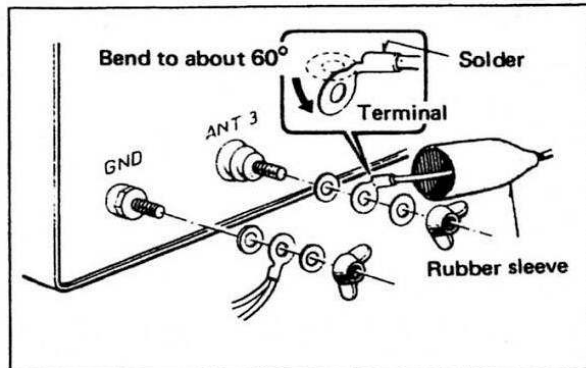

TUNE POSITION MEMO

We recommend using the supplied card to record your antenna data.

It will prove useful when changing BANDs or Antennas.

SECTION 4. CIRCUIT DESCRIPTION

Figure 12 is block diagram of your AT-230.

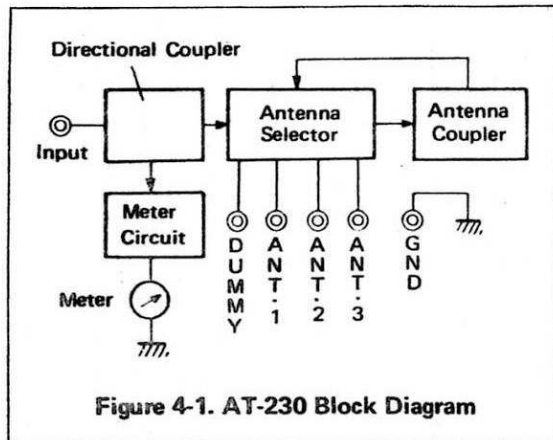

Directional Coupler

The directional coupler separates and samples the forward and reflected power from the coaxial cable connected from the transceiver to the load. The directional coupler used in your AT-230 provides flat frequency response in all ranges of operation by using a toroidal coil. Therefore you do not need a calibration table.

Meter Circuit

The forward and reflected signals taken from the directional coupler are used for power and SWR measurements. In the power measurement mode, the meter can read either forward or reflected power on either the 200W or 20W scales. In the SWR measurement mode, forward power is calibrated with the CAL control so that the meter reads the reflected power as SWR.

Antenna Selector

The antenna selector can connect one of three antennas or a dummy load by a single switch.

Antenna Coupler

This antenna coupler is a universal matching type that is capable of matching 10 Ω to 500 Ω loads to the 50 Ω input impedance.

The advantages are a low insertion loss realized with the use of a low-loss toroidal core and great harmonic attenuation that is effective in reducing TVI and similar radio interference.

SECTION 5. ADJUSTMENT AND MAINTENANCE

Adjustment

Your AT-230 was completely adjusted at the factory. The internal adjustments (VR1 through VR3) are for precisely adjusting the meter circuit. Do not touch them. Should your AT-230 need adjustment or service, please consult your authorized KENWOOD dealer or the factory.

Maintenance

1. To remove the case

Upper case: Remove two top screws and six side screws. Lift up for removal.

Lower case: Do not remove the lower case. This is the Chassis.

2. To install the extension feet (Figure 5-1)

Installing the extension feet raises the front approximately 15 mm, inclining the panel forward.

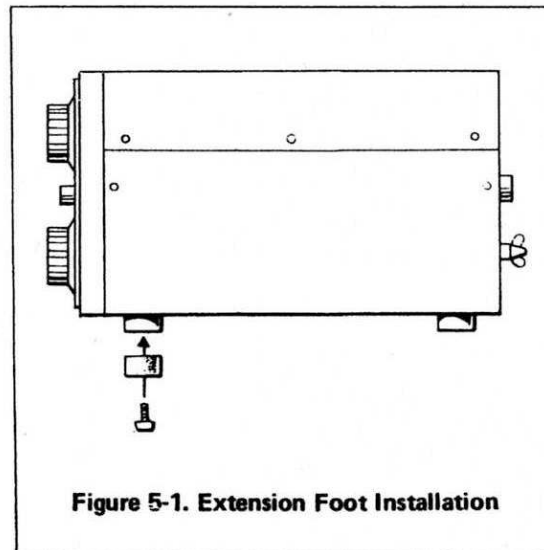

SCHEMATIC DIAGRAM

The circuit elements may be changed without to notice owing to technical innovation.

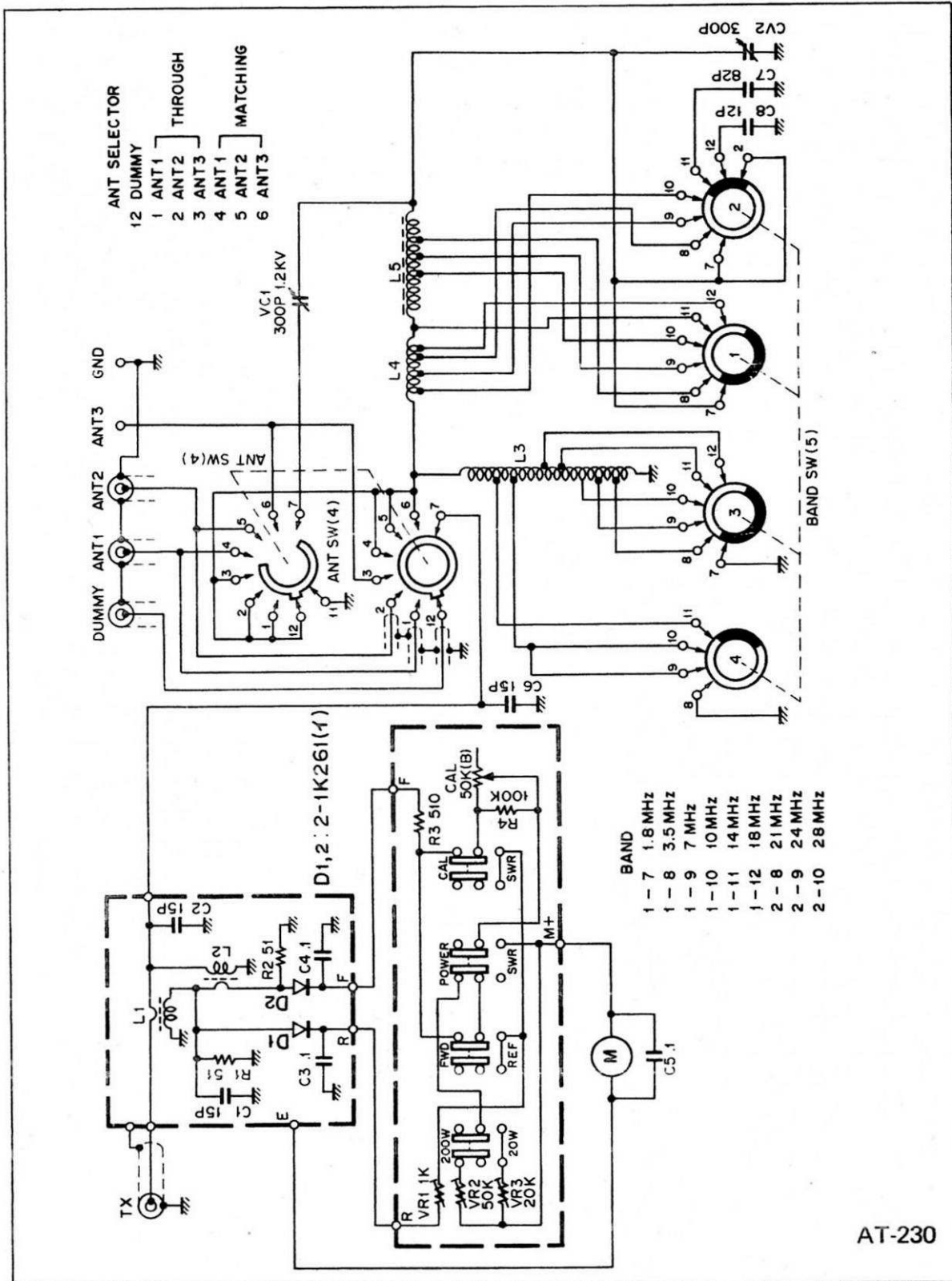

Tune Position Memo

Position Band	ANT 1		ANT 2		ANT 3	
	R	X	R	X	R	X
1.8						
3.5						
7.0						
10.0						
14.0						
18.0						
21.0						
24.5						
28.0						



TRIO-KENWOOD CORP.

Printed in Japan
B59-0404-08

Model AT-230
Serial No. _____
Date Purchased ____ / ____ / ____
Dealer _____

A product of
TRIO-KENWOOD CORPORATION
17-5, 2-chome, Shibuya, Shibuya-ku, Tokyo 150, Japan

TRIO-KENWOOD COMMUNICATIONS, INC.
111, West Walnut Street, Compton, California, 90220, U.S.A.
TRIO-KENWOOD COMMUNICATIONS, GmbH
D-6374 Steinbach TS, Industriestrasse 8A, West Germany
TRIO-KENWOOD (AUSTRALIA) PTY. LTD.
30 Whiting Street, Artarmon, Sydney N.S.W. Australia 2054

© 05106 PRINTED IN JAPAN B50-2756-08 (KO)