



CC-29A

2m CRYSTAL CONTROLLED CONVERTER

R-599A INSTALLATION INSTRUCTIONS

Manufactured by
TRIO ELECTRONICS, INC., TOKYO, JAPAN

1. INSTALLATION

Prior to installation, check whether the package contains the following accessories:

- SO-239 coax receptacle 1
- Resistor (1 k Ω , 1/4W) 1
- Screws (3 x 6) 6
- Nuts 2
- Hexagonal bushings. 4

Mount the printed board of the 144 MHz crystal converter in position on the top of the R-599A receiver chassis. This can be done by merely opening the top lid of the cabinet, but work will be easier if this cabinet is dismantled in advance. Then remove the blanking plate of the 144 MHz ANTANNA hole on the rear panel. Insert the SO-239 coax receptacle in this hole. A coaxial cable is connected to terminals 1 and 2 of the printed board. Connect the other end of this cable with the receptacle by soldering.

Installation is finished when the MT7 pin plug has been inserted in J1 of the fixed channel unit (X50-1140-10).

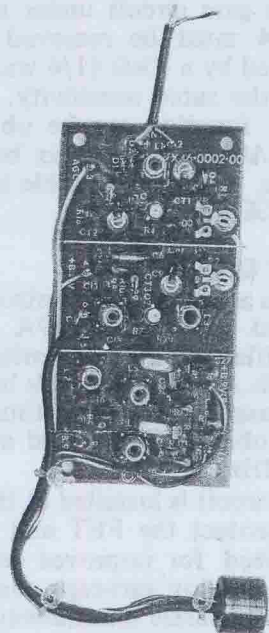

Fig. 1 External View of CC-29A

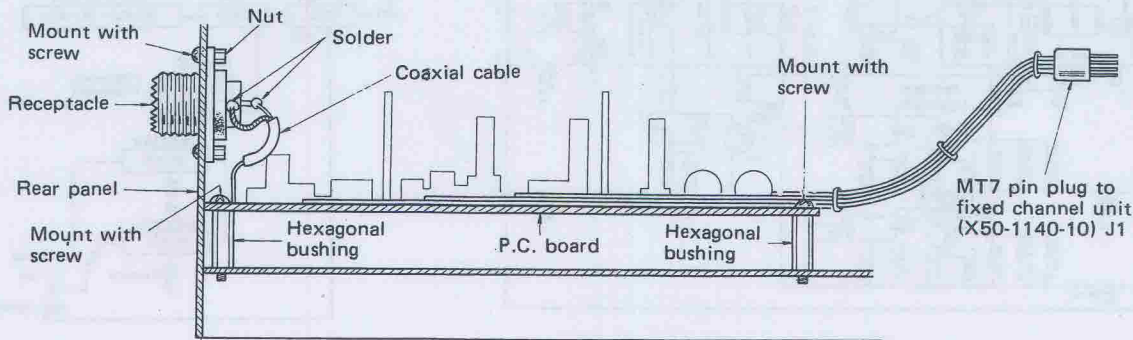

Fig. 2 Mounting of P.C. Board & Receptacle

2. OPERATING INSTRUCTIONS

Connect the antenna to the SO-239 coax receptacle. Set the main band switch to 28 MHz and the auxiliary band switch to A or B, whichever is desired. Remember that the received frequency in this case will not correspond to the receiver dial setting. The relation between them is shown in Fig. 3.

Note: When a 28 MHz band receiver other than the R-599A is used, this converter will operate if the supplied voltages are the same as those indicated in the wiring diagram. However, since this converter uses a special AGC circuitry, which applies a plus voltage to the gate circuit under no signal conditions, R4 must be removed and D3 must be replaced by a 1 k Ω (1/4 watt) resistor to obtain the rated sensitivity. In this case the AGC function can be obtained if the receiver's AGC output varies between 0 volt and minus. It is also possible to receive without the AGC function.

3. CIRCUIT OPERATION

CC-29A is a 2m crystal controlled converter designed for the R-599A receiver. Both RF amplifier and mixer circuits employ FET's and both A and B channels have independent local oscillator circuits, thus making it possible to obtain a converted output of 28.0 ~ 29.7 MHz.

A diode circuit is installed at the antenna input to protect the FET and an AGC circuit is utilized for improved selectivity. Tuned circuits employ vari-caps and the resonance frequency varies simultaneously with a change of channels for better sensitivity and selectivity. The received signal frequencies, local oscillator frequencies, etc., are as specified next table.

Relation of Received & Local Frequencies

Channel	Received freq. (MHz)	Converted output (MHz)	Local OSC freq. (MHz)	Remarks
144MHz-A	144.0~145.7	28.0~29.7	116.0	38.666 MHz (Tripllicated)
144MHz-B	145.7~147.4	28.0~29.7	117.7	39.233 MHz (Tripllicated)

4. ADJUSTMENT

This converter unit has been completely adjusted at the factory and can be operated immediately since it requires no further adjustment. If after long use, however, it is desired to make adjustment, the following method will apply:

For CHANNEL-144MHz-A (parts in the parentheses are for CHANNEL-144MHz-B), adjust CT1 and CT3 (VR1 and VR2) so that the S meter can indicate a maximum deflection. CT2 functions as a neutralizer. It can be turned slowly for adjustment if stable oscillation cannot be obtained. L5 (L6) is an oscillating coil with a core which should be turned clockwise by about a quarter turn from the maximum point of oscillation. The core of the tripler coil L7 should be adjusted to the maximum deflection at the S meter.

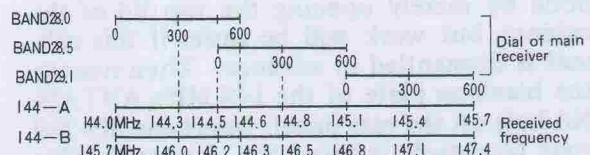
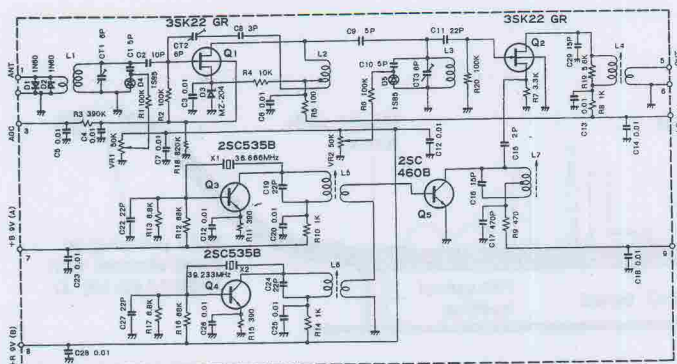
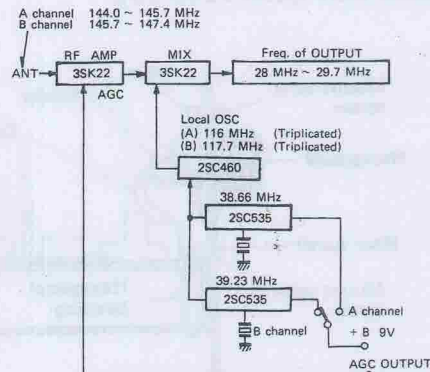

Fig. 3 Relation of Main Receiver's Dial & Received Frequency



(a) Wiring Diagram



(b) Block Diagram

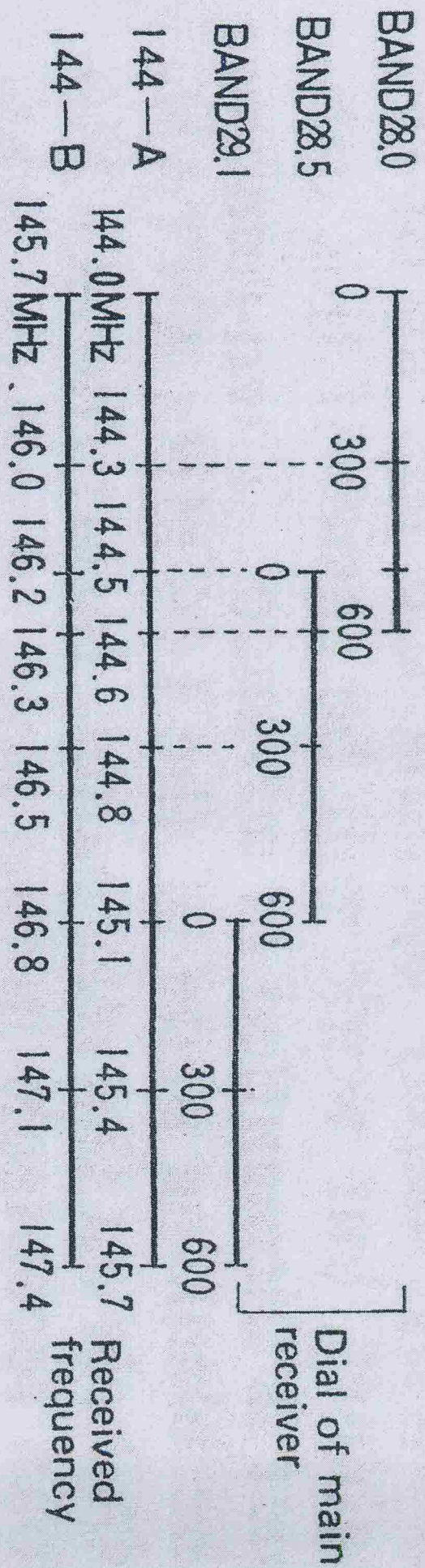

Fig. 3 Relation of Main Receiver's Dial & Received Frequency



CC-69A

6m CRYSTAL CONTROLLED CONVERTER

R-599A INSTALLATION INSTRUCTIONS

Manufactured by
TRIO ELECTRONICS, INC., TOKYO, JAPAN

1. INSTALLATION

Prior to installation, check whether the package contains the following accessories:

- SO-239 coax receptacle 1
- Resistor (1 kΩ, 1/4W) 1
- Screws (3 × 6) 6
- Nuts 2
- Hexagonal bushings 4

Mount the printed board of the 50 MHz crystal converter in position on the top of the R-599A receiver chassis. This can be done by merely opening the top lid of the cabinet, but work will be easier if this cabinet is dismantled in advance. Then remove the blanking plate of the 50 MHz ANTENNA hole on the rear panel. Insert the SO-239 coax receptacle in this hole. A coaxial cable is connected to terminals 1 and 2 of the printed board. Connect the other end of this cable with the receptacle by soldering. Installation is finished when the MT7 pin plug has been inserted in J2 of the fixed channel unit (X50-1140-10).

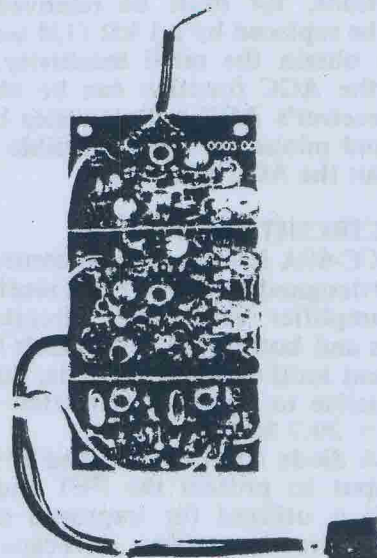

Fig. 1 External View of CC-69A

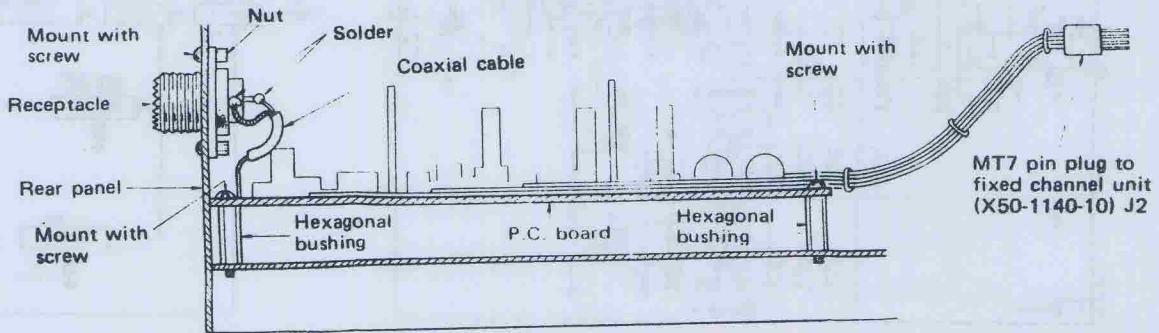

Fig. 2 Mounting of P.C. Board & Receptacle

2. OPERATING INSTRUCTIONS

Connect the antenna to the SO-239 coax receptacle. Set the main band switch to 28 MHz and the auxiliary band switch to A or B, whichever is desired. Remember that the received frequency in this case will not correspond to the receiver dial setting. The relation between them is shown in Fig. 3. Note: When a 28 MHz band receiver other than the R-599A is used, this converter will operate if the supplied voltages are the same as those indicated in the wiring diagram. However, since the converter uses a special AGC circuitry, which applies a plus voltage to the gate circuit under no signal conditions, R4 must be removed and D3 must be replaced by a 1 k Ω (1/4 watt) resistor to obtain the rated sensitivity. In this case the AGC function can be obtained if the receiver's AGC output varies between 0 volt and minus. It is also possible to receive without the AGC function.

3. CIRCUIT OPERATION

CC-69A is a 6m crystal controlled converter designed for the R-599A receiver. Both RF amplifier and mixer circuits employ FET's and both A and B channels have independent local oscillator circuits, thus making it possible to obtain a converted output of 28.0 ~ 29.7 MHz.

A diode circuit is installed at the antenna input to protect the FET and an AGC circuit is utilized for improved selectivity. Tuned circuits employ vari-caps and the resonance frequency varies simultaneously with a change of channels for better sensitivity and selectivity. The received signal frequencies, local oscillator frequencies, etc., are as specified next table.

Relation of Received & Local Frequencies

Channel	Received freq. (MHz)	Converted output (MHz)	Local OSC freq. (MHz)	Remarks
50MHz A	50.0~51.7	28.0~29.7	22.0	Overtone
50MHz B	51.7~53.4	28.0~29.7	23.7	Overtone

4. ADJUSTMENT

This converter unit has been completely adjusted at the factory and can be operated immediately since it requires no further adjustment. If after long use, however, it is desired to make adjustment, the following method will apply:

For CHANNEL-50MHz-A (parts in the parentheses are for CHANNEL-50MHz-B), adjust CT1, CT3, and CT4 (VR1, VR2, and VR3) so that the S meter can indicate a maximum deflection. CT2 functions as a neutralizer. It can be turned slowly for adjustment if stable oscillation cannot be obtained. L4 (L5) is an oscillating coil with a core which should be turned clockwise by about a quarter turn from the maximum point of oscillation.

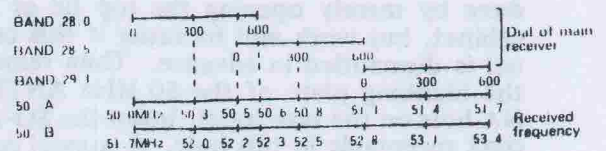
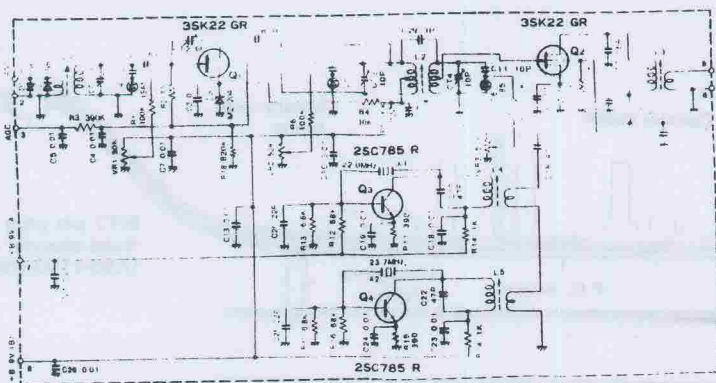
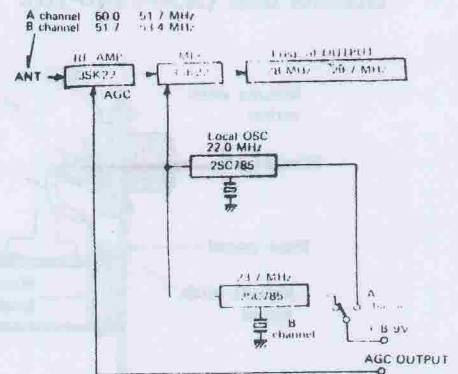

Fig. 3 Relation of Main Receiver's Dial



(a) Wiring Diagram



(b) Block Diagram

