

 **KENWOOD**

**SSB
TRANSCEIVER**

TS-520 SERIES
TS-520/VFO-520/SP-520



TS-520 DX HUNTER.....POWERFUL QS

The TS-520 is the final word in SSB transceivers, a superb creation from Kenwood, designed and built for serious enthusiasts around the world. It features solid state circuit throughout except for the final and drive stages.

1. Heavy Die-Cast Front Panel

Lasting sensitivity, selectivity and stability constitute the basic prerequisites for communications gear. The TS-520 is a superb creation providing the ultimate not only in sensitivity and selectivity but in stability, which is regarded as perhaps the most important single requisite for ham equipment. For example, the front panel is assembled by rugged die-cast. The VFO housing is attached to this sturdy front panel. It is thus designed to withstand the rigors of mobile or field operation.

2. Outstanding Receiver Sensitivity and Minimum Cross Modulation

The TS-520 is a superb HF SSB/CW transceiver in which Kenwood's solid state engineering capabilities have been put to full use. Solid state circuit is employed throughout except for the driver and final stages, for the highest standards of reliability and stability.

Dual gate MOS FET 3SK35, which have low feedback capacity (C_{rss}) and provide outstanding cross modulation and spurious response characteristics, are used in all key RF circuits, to provide both outstanding sensitivity and minimum cross modulation.

Features of Silicon Dual Gate MOS FET 3SK35

- Low feedback capacity: $C_{rss}=0.02$ pf (Typ.)
- Low noise: NF=3.5 dB (Typ.)

(f=200 MHz)

- High power gain: Gps=18 dB (Typ.) (f=200 MHz)
- Outstanding cross modulation and spurious response characteristics
- Wide AGC range

3. Mobile and Field Capability

The TS-520 is a compact, all-in-one transceiver with its own built-in AC/DC power supply and speaker. A unique heater ON-OFF circuit (PT. PEND.) is provided to minimize power consumption when receiving only.

4. Highly Effective Noise Blanker Circuit

An effective noise blanking circuit developed by Kenwood that virtually eliminates ignition noise built in the TS-520.

5. 2-Position Amplified-Type ALC Circuit

An amplified-type ALC circuit is used, for vastly improved rise characteristic and excellent compression. The operator observes the ALC meter to maintain the transceiver in optimum operating condition at all. Two positions are provided for the ALC circuit, LOCAL and DX. The TS-520 is designed to increase talk power without impairing tonal quality of the voice, a design feature which in fact has long been a Kenwood SSB specialty.

6. Dial Provides 100 KHz Coverage Per Turn

A combination of high precision gear and direct-reading VFO provides 1 KHz dial readout. The main turning knob and main dial scale feature a unique drive mechanism with a reduction ratio of approximately 4 : 1.

7. 8-Pole Crystal Filter

An 8-pole high performance, high-frequency type crystal filter is used to provide truly outstanding selectivity. Available as an option is the YG-3395C CW filter.

8. A Kenwood Exclusive: High Stability FET VFO

The VFO, the heart of an SSB transceiver, is an exclusive Kenwood design using FET. The housing of the VFO which serves to protect the components from vibrations and shocks in mobile or field use and assure lasting stability is a large heavy gauge deep drawing aluminum case.

9. Equipped With Pushbutton Switch For Reception Of WWV Standard Wave

The WWV switch enables instantaneous reception of WWV standard wave (10 MHz), regardless of that band the transceiver may be working. This is a highly convenient feature for market calibration or for ascertaining atmospheric conditions.

10. Built-in 25 KHz Marker

While it is of course possible to calibrate the dial by reception of the WWV standard wave, for even more precise calibration.



SP-520

TS-520

VFO-520

.....MINIMUM CROSS MODULATION

TS-520 "SPLIT FREQUENCY CONTROL" Operation

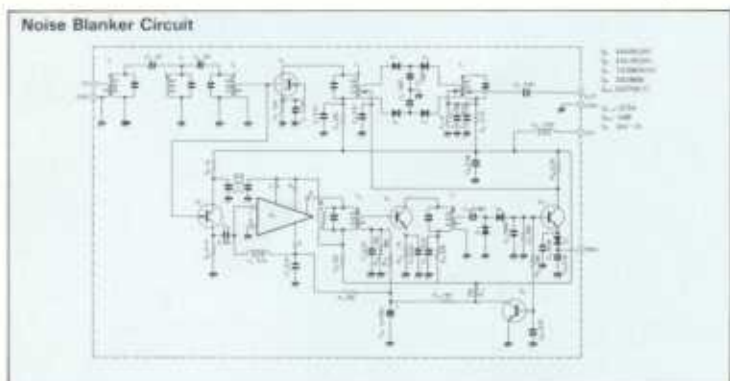

		TS-520 FUNCTION				CAL			
		VFO	VFO-R	FIX-R	FIX	25kHz	RMT	FIX	
VFO-520 FUNCTION	OFF	RECEIVE	MAIN	MAIN	FIX	FIX	MAIN	M	FIX
	TRANSMIT	MAIN	FIX	MAIN	FIX	R		MAIN	
REC	RECEIVE	RMT	RMT	FIX	FIX	RMT	M	FIX	
	TRANSMIT	MAIN	FIX	MAIN	FIX		R	RMT	
REC/XMIT	RECEIVE	RMT	RMT	FIX	FIX	RMT	M	FIX	
	TRANSMIT	RMT	FIX	RMT	FIX		R	RMT	
XMIT	RECEIVE	MAIN	MAIN	FIX	FIX	MAIN	M	FIX	
	TRANSMIT	RMT	FIX	RMT	FIX		R	MAIN	

• Main: Internal VFO • RMT: External VFO • Nine combinations are available.

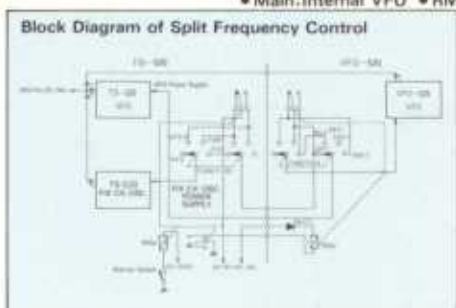
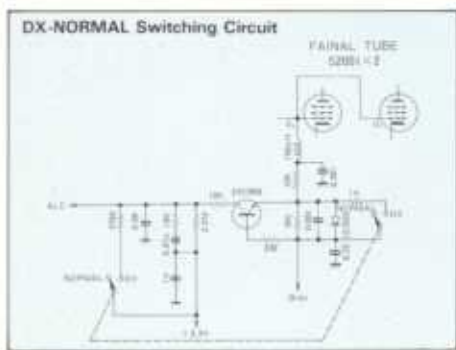

11. Carrier Level Control On Front Panel

Both the mic gain and carrier level controls are placed on the front panel for convenient use.

12. Amplified-Type AGC Circuit With 3 Positions

An amplified-type AGC circuit is provided to prevent distortion at strong signal inputs for top quality SSB reception. The time constant can be switched to

any of three positions (OFF-FAST-SLOW) to enable the transceiver to be operated in optimum condition at all times regardless of whether in the SSB or CW mode.

13. Provision For Up To Four Fixed Channels

The TS-520 can also be operated with up to four fixed channels (crystals are optional). The function switch can be set to provide split frequency control using a fixed channel oscillator and VFO. For instance, if the other station's frequency should drift while working on a

fixed channel, the receiving frequency can be controlled by the VFO for optimum reception.

14. External VFO: VFO-520 (Optional)

Split frequency control can be used with either VFO-520 or FIX ch. oscillator. Connecting the VFO-520 with the TS-520 is accomplished with a single cable.

15. Threshold Type RF Gain Control

The RF gain control circuit is the threshold type which provides accurate S-meter indications.

Other features: • Semi break-in with side tone • VOX/PTT/MOX circuit • RIT circuit • Tune position switch • VFO indicator/RIT indicator/FIX ch. indicator (each indicator consists of light-emitting diode) • Meter switch (S/ALC-IP-RF-HV) • Cooling fan • Transverter terminals • Speaker • Heater switch • Linear amplifier terminal • Headphones and external speaker terminals

TS-520.....Specifications

Frequency Range	80 meter band - 3.50 to 4.00 MHz 40 meter band - 7.00 to 7.30 MHz 20 meter band - 14.00 to 14.35 MHz 15 meter band - 21.00 to 21.45 MHz 10 meter band - 28.00 to 28.50 MHz 28.50 to 29.10 MHz 29.10 to 29.70 MHz WWV - 10.00 MHz (Receive only) USB, LSB, CW
Mode	
Input Power	160 watts on 80 to 15 meter band, 140 watts on 10 meter band
Antenna Impedance	50 to 75 ohms, unbalanced
Carrier Suppression	40 dB
Unwanted Sideband Suppression	40 dB
Harmonic Radiation	-40 dB
AF Response	400 to 2,600 Hz (-6 dB)
Audio Input	
Sensitivity	High impedance (50 kΩ) 0.5 μV for 10 dB (S+N)/N on 80 to 15 meter band

Selectivity	1.0 μV for 10 dB (S+N)/N on 10 meter band SSB: 2.4 kHz (-6 dB) 4.4 kHz (-60 dB) CW: 0.5 kHz (-6 dB) 1.5 kHz (-60 dB) (with optional CW filter)
Frequency Stability	100 Hz per 30 minutes after warm-up.
Image Ratio	50 dB
IF Rejection	50 dB
AF Output Power	1 watt (with 8 ohms load and 10% H.D.)
AF Output Impedance	4 to 16 ohms (Speaker or Headphone)
Tube and Semiconductor Complement	3 tubes (2 × 52001, 12BY7A), 1 IC, 18 FET's, 44 transistors, 84 Diodes
Power Requirements	120/220 VAC, 50/60 Hz Transmit : 280 watts Receive : 26 watts (with heater-off) or 13.8 VDC Transmit : 15 Amp. Receive : 0.6 Amp.
Dimensions	333 (13.11) wide × 150 (5.91) high × 335 (13.19) deep mm (inch)
Weight	16 kg (35.2 Lbs.)

VFO-520.....Specifications

Frequency Range	5.5 to 4.9 MHz
Output Voltage	1.0 volt, -3 dB (with 470 ohms termination resistor)
Frequency Stability	100 Hz per 30 minutes after warm-up.
Semiconductor Complement	2 FET's, 2 transistors, 7 diodes
Power Requirements	Supplied from TS-520
Dimensions	166 (6.54) wide × 150 (5.91) high × 190 (7.48) deep mm (inch)
Weight	3 kg (6.6 Lbs.)

SP-520.....Specifications

Speaker Diameter	12 cm (4.72")
Maximum Input Power	2 watts
Impedance	8 ohms
Frequency Response	100 to 5,000 Hz
Dimensions	160 (6.30) wide × 150 (5.91) high × 190 (7.48) deep mm (inch)
Weight	1.4 kg (3.08 Lbs.)

Specifications and designs are subject to change without notice.

Electrical Characteristics

Transmitting output characteristic

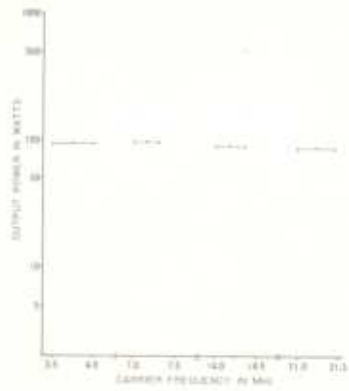

Transmitting output characteristic

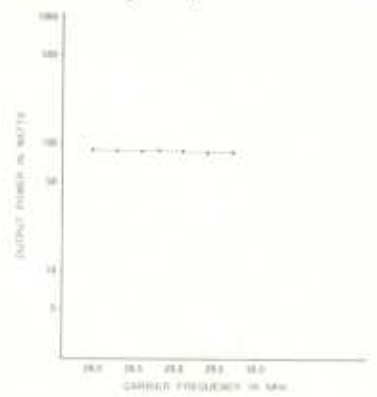

Receiving sensitivity characteristic

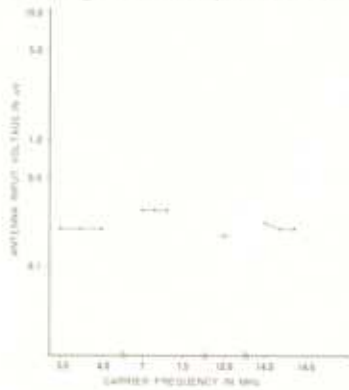

Receiving sensitivity characteristic

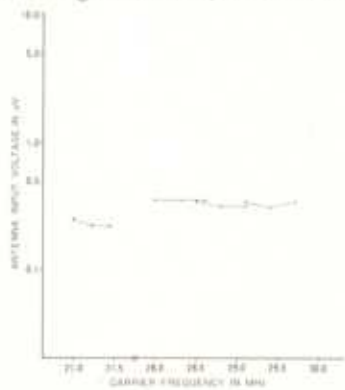

Transmitting frequency characteristic

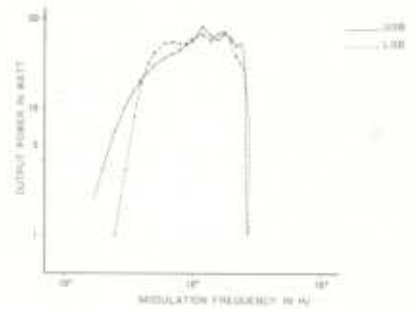

Image ratio and IF interference ratio

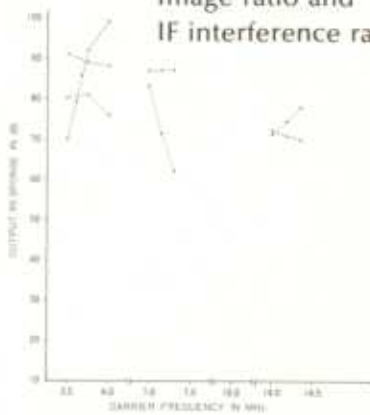
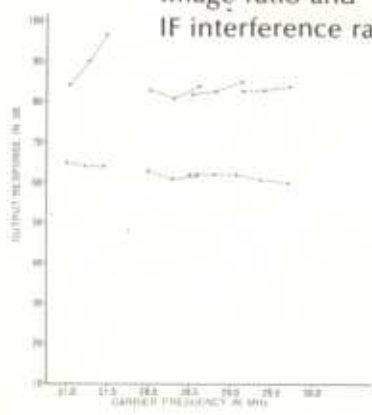
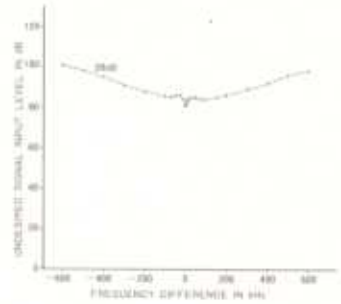

Image ratio and IF interference ratio



Receiving cross-modulation characteristic



Blocking

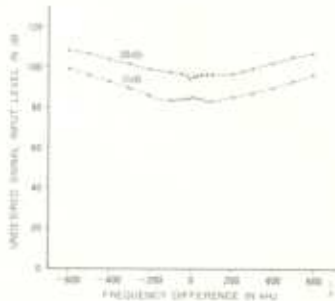

Crystal filter characteristic



One signal selectivity characteristic

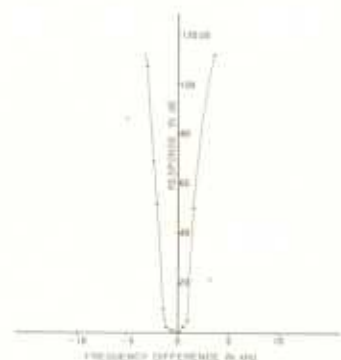

TS-520 BLOCK DIAGRAM

Table 1 Carrier Frequency

	Rec.	Trans.
L S B	3.3935 MHz	3.3935 MHz
U S B	3.3965 MHz	3.3965 MHz
C W	3.3943 MHz	3.3950 MHz

Table 2 Hel. Frequency

BAND	Frequency	BAND	Frequency
3.5 MHz	17.395 MHz	28 MHz	36.895 MHz
7 MHz	15.895 MHz	28.5 MHz	37.395 MHz
14 MHz	27.895 MHz	29.1 MHz	37.895 MHz
21 MHz	29.895 MHz		

Table 3 Fix. Xtal

TYPE	HC-25U
Frequency	5.5-4.9 MHz

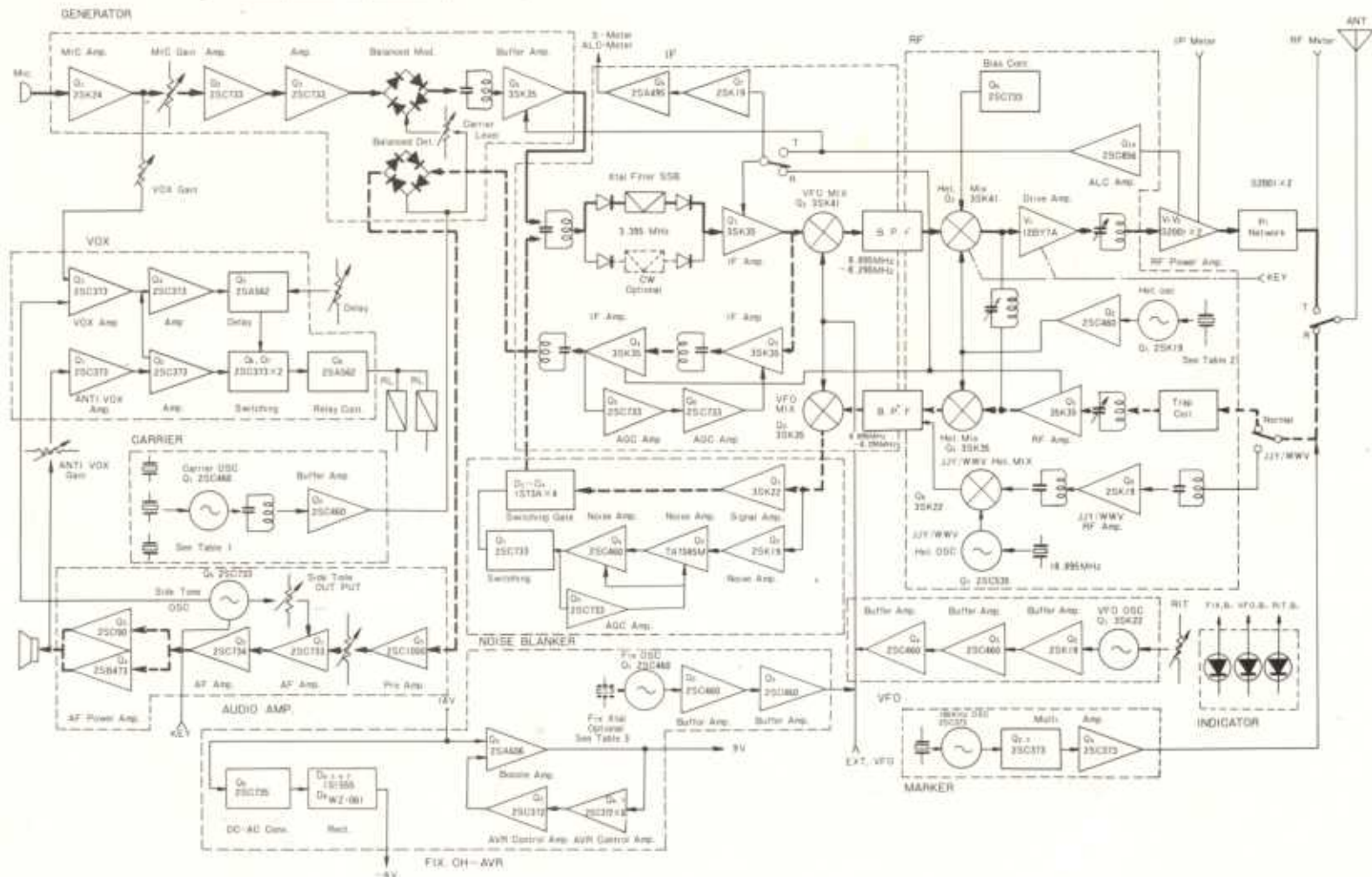

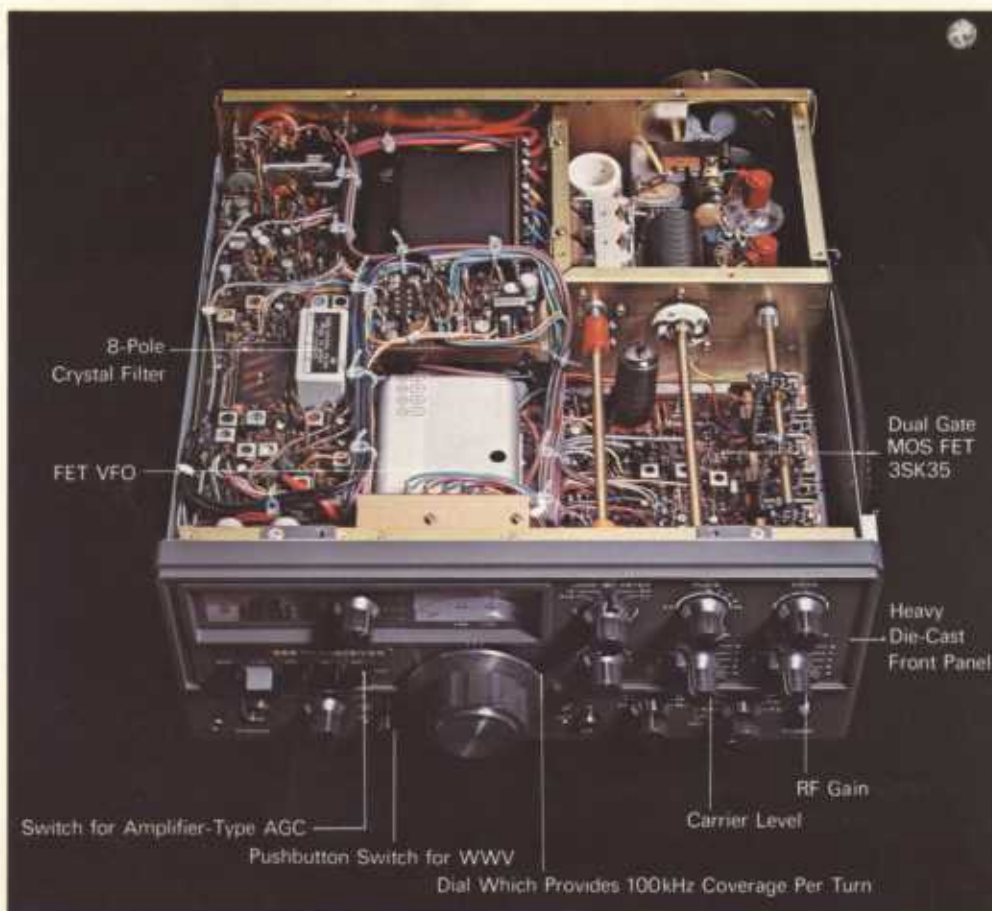

Model VFO-520 External VFO

Designed for high stability with precision gear and deep drawing aluminum housing.

* Through the combination of precision gear and a linear dial scale, dial readout is 1 kHz. Dial knob and main dial scale feature a unique drive mechanism with a reduction ratio of 4 : 1, assuring smooth tuning.

* VFO circuit, which is the heart of the transceiver, uses FET for high stability.

* RIT circuit equipped with indicator showing state of operation.

* Function switch makes possible any combination of the TS-520 and the external VFO-520. The VFO-520 and TS-520 are equipped with VFO indicators which enable the operator to see at a glance which VFO is being used.

* The external VFO-520 is connected to the TS-520 transceiver with a single cable. It obtains its power supply from the TS-520.

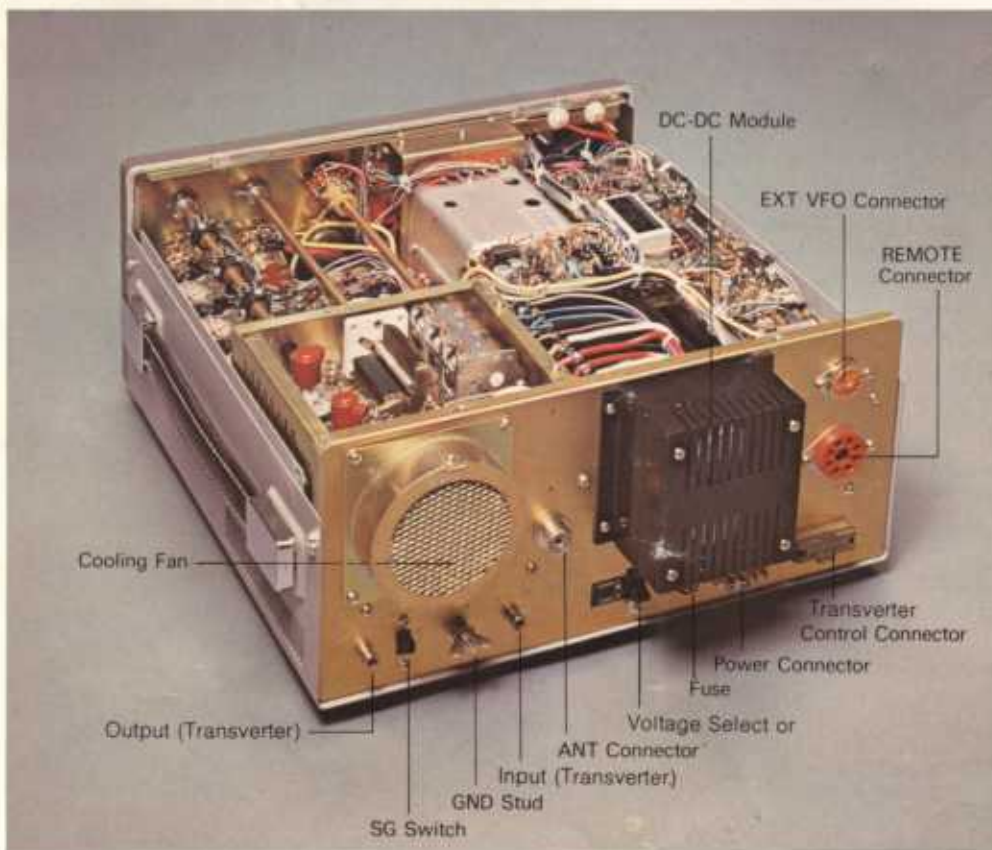

Model SP-520 External Speaker

* The TS-520 has built-in speaker. However, by using the SP-520 external speaker which matches the TS-520 in both design and performance, operation with improved tonal quality is provided.



A product of
TRIO ELECTRONICS, INC.
 6-17, 3-CHOME, AOBADAI, MEGURO-KU, TOKYO, JAPAN

(M1750110D Printed in Japan)